

# Passive houses in Sweden

Experiences from design and construction phase

*Ulla Janson*

---

Division of Energy and Building Design  
Department of Architecture and Built Environment  
Lund University  
Faculty of Engineering LTH, 2008  
Report EBD-T-08/9



## Lund University

Lund University, with eight faculties and a number of research centres and specialized institutes, is the largest establishment for research and higher education in Scandinavia. The main part of the University is situated in the small city of Lund which has about 105 000 inhabitants. A number of departments for research and education are, however, located in Malmö. Lund University was founded in 1666 and has today a total staff of 6 000 employees and 42 500 students attending 90 degree programmes and 1 000 subject courses offered by 74 departments.

## Division of Energy and Building Design

Reducing environmental effects of construction and facility management is a central aim of society. Minimising the energy use is an important aspect of this aim. The recently established division of Energy and Building Design belongs to the department of Architecture and Built Environment at the Lund University, Faculty of Engineering LTH in Sweden. The division has a focus on research in the fields of energy use, passive and active solar design, daylight utilisation and shading of buildings. Effects and requirements of occupants on thermal and visual comfort are an essential part of this work. Energy and Building Design also develops guidelines and methods for the planning process.

# Passive houses in Sweden

Experiences from design  
and construction phase

Ulla Janson

Licentiate Thesis

## Keywords

Passive house, Energy efficiency, Residential buildings, Building construction, Planning process, Leadership

© copyright Ulla Janson and Division of Energy and Building Design.  
Lund University, Lund Institute of Technology, Lund 2008.  
The English language corrected by L. J. Gruber BSc(Eng) MICE MStructE.  
Layout: Hans Follin, LTH, Lund.  
Cover photo: Ulla Janson

Printed by KFS AB, Lund 2008

Report No EBD-T-08/9  
Passive houses in Sweden. Experiences from design and construction phase.  
Department of Architecture and Built Environment, Division of Energy and Building Design,  
Lund University, Lund

ISSN 1651-8136  
ISBN 978-91-85147-24-3

Lund University, Lund Institute of Technology  
Department of Architecture and Built Environment  
Division of Energy and Building Design  
P.O. Box 118  
SE-221 00 LUND  
Sweden

Telephone: +46 46 - 222 73 52  
Telefax: +46 46 - 222 47 19  
E-mail: [ebd@ebd.lth.se](mailto:ebd@ebd.lth.se)  
Home page: [www.ebd.lth.se](http://www.ebd.lth.se)

# Abstract

The sector of residential buildings and service organizations uses 36% of the total energy in Sweden. In June 2006, it was decided by the Swedish parliament that the energy use in residential buildings and premises should decrease by 20% per heated unit area before 2020. To reach this goal, more energy efficient buildings must be produced as well as energy efficient improvements must be performed on the existing building stock.

One way to reduce the energy use in buildings is to build passive houses. A passive house is a mechanically ventilated building that with a highly insulated and air tight building envelope uses a minimum of energy for heating. The method used in this research is to practically participate in four passive house demonstration projects. The results expected are to find guiding principles and tools needed for passive house planning and make the system solutions usable for planning in more general terms. Joining as a part of the planning group; advice and help is given to architects, consultants and to the client. The demonstration projects studied are located in the south-west of Sweden. Three of the projects are new constructions and one is a renovation project.

In the centre of Värnamo 40 rental apartments were built in 2005/2006 according to the passive house standard. Solar collectors on the roof contribute to the domestic hot water production. Every apartment has its own mechanical ventilation system with efficient heat recovery. Auxiliary heating is supplied by electricity. The load bearing structure were made of concrete and cast at site. The exterior walls and roof were made of wooden frame construction and mounted at site. The tenants moved in during summer 2006.

The passive house project in Frillesås consists of three houses with 12 rental apartments. The air is supplied by mechanical ventilation with an air to air heat exchanger, one in each apartment. The domestic hot water is prepared by solar collectors and auxiliary heating is supplied by district heating. The two storeys are separated by an intermediate floor with a prefabricated filigree system. The wooden outer walls and roof are prefabricated. The tenants moved in during December 2006.

In Lidköping close to Lake Vänern, a single-family house in two storeys was built with passive house standard and has a total living area of 170 m<sup>2</sup>. The house is heated by air. The air is supplied by mechanical ventilation with an air-to-air heat exchanger. The prefabricated blocks in the exterior walls have a wooden frame construction with mineral wool, each made in two parts, mounted at site with a polystyrene layer between. The family moved in during April 2007.

Alingsåshem, the public housing company in Alingsås owns 300 apartments in the Brogården area. These apartments were built in 1970 and are in great need of renovation. The apartments will be renovated aiming to the energy levels of a passive house.

Well accomplished demonstration projects are seen as reference objects and are used as a basis for future projects. The results show that the project leader has here a key role. The proud carpenters with straight backs are priceless as advertisers for building passive houses. It is possible to build passive houses with good results even if the project leader does not lead the project in a perfect way. Skilled contractors and external experts can together create a very good final result. Clear goals that are followed up during the whole process are a key issue. It is expensive to make corrections and changes at a late stage in the project. Lack of good leadership might not affect the final result but the final cost.

# Contents

<b>Keywords</b>	2
<b>Abstract</b>	3
<b>Contents</b>	5
<b>Acknowledgements</b>	9
<b>1 Introduction</b>	11
1.1 The Swedish climate strategy	11
1.2 Energy supply and climate issues	11
1.2.1 Swedish environmental goals	12
1.2.2 Energy efficient buildings	13
1.2.3 Definitions	14
1.3 Object, method and limitations	15
1.3.1 Limitations	16
1.4 Earlier experiences of European passive houses	16
1.4.1 Building envelope	18
1.4.2 Air leakage	18
1.4.3 U-values	19
1.4.4 Ventilation	19
1.4.5 Space heating	20
1.4.6 The CEPHEUS project	22
1.4.7 PEP: Promotion of European Passive Houses	23
1.5 Passive houses in Sweden	24
1.5.1 Requirements regarding peak load for space heating	24
1.5.2 Maximum power to be used in the ventilation air heating	25
1.5.3 Energy demand	26
1.5.4 Domestic hot water	27
1.5.5 Building requirements	28
1.5.6 Sound	28
1.5.7 Supply air temperature	28
1.5.8 Measurements	28
1.5.9 Household appliances	29
1.6 Earlier experiences of Swedish Passive House Projects	29
1.6.1 The Lindås project	29
1.6.2 Glumslöv	30

<b>2</b>	<b>Introduction to the demonstration projects</b>	33
2.1	Oxtorget – Värnamo	33
2.2	Karl Johans väg – Frillesås	36
2.3	Villa Malmborg – Lidköping	41
2.4	Brogården – Alingsås	43
<b>3</b>	<b>Apartment buildings in Värnamo, Oxtorget</b>	49
3.1	Decision	49
3.2	Basic requirements	50
3.3	Planning	50
3.4	Constructions	51
3.4.1	HVAC system	53
3.4.2	Domestic hot water system	54
3.5	Simulations	56
3.5.1	Calculated results	57
3.6	Tendering	58
3.7	Planning deviations	58
3.7.1	Heat recovery from sewage water	58
3.7.2	Windows	58
3.7.3	Airtightness	59
3.8	Education	59
3.9	The construction stage	60
3.9.1	Foundation construction	60
3.9.2	Loadbearing structure	61
3.9.3	Exterior walls	62
3.9.4	Roof construction	68
3.9.5	Ventilation	70
3.9.6	Domestic hot water system	71
3.10	Measurements	71
3.10.1	Airtightness	71
3.10.2	Sound	72
3.10.3	Household measurements	73
3.11	Economy	73
3.11.1	Specific additional costs	74
3.11.2	Rental costs	75
3.12	Additional Experiences	75
<b>4</b>	<b>The Frillesås project</b>	77
4.1	Decision	77
4.2	Basic requirements	78
4.3	Planning	78
4.4	Constructions	79
4.4.1	HVAC – system	80
4.4.2	Domestic hot water system	82
4.4.3	Household appliances	84



4.5	Simulations	85
4.5.1	Calculated results	86
4.6	Tendering	87
4.7	Planning deviations	87
4.7.1	Entry doors	87
4.8	Training	88
4.9	The construction stage	89
4.9.1	Foundation construction	89
4.9.2	Loadbearing structure	90
4.9.3	Exterior walls and windows	91
4.9.4	Roof construction	95
4.9.5	Ventilation	97
4.9.6	Domestic hot water	98
4.10	Measurements	98
4.10.1	Airtightness	98
4.10.2	Airtightness measured for the building envelope alone	101
4.11	Moisture	104
4.11.1	Method of measurements	104
4.12	Further measurements	106
4.12.1	Measuring methods	106
4.13	Economy	106
4.14	Additional experiences	107
<b>5</b>	<b>Villa Malmberg</b>	<b>111</b>
5.1	Decision	111
5.2	Basic requirements	112
5.3	Planning	113
5.4	Constructions	114
5.4.1	HVAC system	116
5.4.2	Domestic hot water system	117
5.4.3	Household appliances	117
5.5	Simulations	118
5.5.1	Calculated results	120
5.6	Tendering	120
5.7	Planning deviations	120
5.8	Training	123
5.9	The building process	124
5.9.1	Foundation construction	124
5.9.2	Loadbearing structure	125
5.9.3	Exterior walls	125
5.9.4	Roof construction	137
5.9.5	Ventilation system	139
5.9.6	Domestic hot water	140
5.10	Measurements	140
5.10.1	Airtightness	140

5.10.2	Moisture	142
5.10.3	Further measurements	143
5.11	Economy	143
5.12	Additional experiences	144
<b>6</b>	<b>Additional analyses</b>	<b>147</b>
6.1	Temperature variations when the loadbearing construction in Villa Malmborg is changed	148
6.1.1	Energy demand	149
6.1.2	Indoor temperature	150
6.2	Variation in indoor temperatures in Villa Malmborg when not using the house for two weeks	154
6.2.1	Wooden frame construction – temperature variations	154
6.2.2	Concrete construction – temperature variations	156
6.2.3	Influence of the thermal inertia when the house is unoccupied for a period	157
6.3	Energy demand using regular insulation thickness in the multifamily houses in Frillesås	158
6.4	Space heating with supply air in Värnamo	160
6.4.1	Simulations with indoor temperature of 20°C	161
6.4.2	Simulations with indoor temperature of 22°C	162
6.4.3	Simulations with indoor temperature of 24°C	163
<b>7</b>	<b>Project leadership</b>	<b>167</b>
7.1	To order something you do not really have knowledge about	168
7.2	Right competence	169
7.3	To discover something unexpected	169
7.4	Leadership	170
7.4.1	Leadership in the projects	171
7.4.2	Influence of the leadership on work on site and the final result	173
<b>8</b>	<b>Discussion and conclusions</b>	<b>175</b>
	<b>Summary</b>	<b>179</b>
	<b>References</b>	<b>187</b>
	<b>Appendix A</b>	<b>191</b>

# Acknowledgements

This research is funded by the Swedish Energy Agency. Thank you for making this possible.

I would like to thank the property owners and contractors for building such fabulous passive houses and letting me be part of it. Thank you for always taking time to answer my questions and being so positive.

I also wish to thank everyone at the division of Energy and Building Design for being supportive and helpful, especially my supervisor Maria Wall, who always manages to have time for me.

Finally, I wish to thank all friends and my family for cheering me up. A special thanks to my parents; without you I would still be trying to learn the names of the dinosaurs.

Lund, February 2008

Ulla Janson



# 1 Introduction

## 1.1 The Swedish climate strategy

Around the world, the challenges regarding energy policy issues are almost the same. The supply of energy should be safe, environmentally friendly and supplied at a decent cost. Taking measures towards more energy efficient solutions and making investments in renewable energy sources have the potential to conduce to all these three goals.

The Swedish ratification of the Kyoto Protocol and the United Nations Framework Convention on Climate Change are used as a basis for decisions regarding the Swedish climate strategy. The goals for the Swedish energy policy were provided in 1997 (prop 1996/97:84), when a strategy for the continuous work on the modification of the energy system was also compiled. The guiding principles of the energy policy were confirmed in 2002 when the government bill was accepted by the Swedish parliament (prop 2001/02:143). The Swedish energy supply should be effective and sustainable over time. The principles insist on the necessity to secure the energy supply and the supply of electricity under competitive conditions relative to the rest of the world, in both a short and long term perspective. To achieve this, the political decisions are taken to make the supply cost effective with low negative effects on health, the environment and climate. The decisions should also make it easy to change already existing energy supply arrangements towards a more ecologically sustainable society. Renewable heat sources and energy efficiency are areas prioritised.

## 1.2 Energy supply and climate issues

The total energy use in the Swedish industry and building sector today is almost at the same level as in 1970, even though the total heated area has increased, the total population is 11% more and industrial production is much higher than in 1970 (Energiläget, 2006).

The sector of dwellings and service organizations uses 36% of the total energy in Sweden. Of these 36%, 87% is used for residential and non-residential buildings, mostly (60%) for heating and domestic hot water but also for fans, pumps and other building services. The use of energy in buildings varies between the years, mostly due to differences in outdoor temperatures (Energiläget, 2006).

In 2005, 85.3 TWh was used for space heating and domestic hot water in residential and non-residential buildings in Sweden. Of these 42% were used in single family houses, 32% in multifamily houses and 26 % in offices, business stores and public buildings. The energy used was mostly district heating and electricity. In multi family houses district heating is the most common form of heating. In single-family houses 7% were using district heating and 22% electricity for heating in 2005. Half of them were using direct electricity and the other half waterborne electricity for heating. The rest of the one-family houses were using oil (4%) and bio fuels (7%). About 11% had a heat pump installed. Direct electricity is used mainly because it is easy to install and easy to handle (Energiläget, 2006).

Measures have been taken to decrease the energy use in buildings. More energy efficient household appliances have been installed, insulation has been added in building constructions and when windows are changed, windows with a lower U-value are used. Unfortunately, this has not resulted in a decreased use of household electricity. The use of household electricity increased from 9.2 to 19.7 TWh between 1970 and 2005, mainly during the 70s and 80s, even though energy efficient household appliances are used. This can be explained by the increased number of households and the number of appliances used in each household. In 2005, the single family houses were using on average 6200 kWh for household electricity per house and year. Apartments were using 40kWh/m<sup>2</sup>a.

### 1.2.1 Swedish environmental goals

In April 1999, the Swedish government agreed on 15 environmental goals, with one additional goal added in November 2005. One of these goals is “A good built environment” and another “A limited influence on the climate” – both goals are important for the building industry. (prop. 2000/01:130) In June 2006, it was decided by the Swedish parliament that the energy use in residential and non-residential buildings should decrease by 20% per heated unit area before 2020 in relation to the energy use in residential buildings in 1995. By the year 2050 the energy use should be halved compared to the energy use in 1995. By 2020 the dependency on fossil fuels for heating buildings must be discontinued (Prop. 2005/06:145).

To reach the stated goals regarding energy use, means of control can be used. Administrative means of control are regulations such as prohibitions or decrees made by political or administrative agencies. These regulations are binding and can be quantitative or technical.

### 1.2.2 Energy efficient buildings

Construction of energy efficient buildings contributes to the environmental goals by considerably decreasing the energy use for heating. In this way, the use of fossil fuels decreases and the emissions of carbon dioxide, air borne particle contaminations, sulphur dioxide etc are reduced.

BBR is the Swedish building regulation where specific demands of total energy use in buildings are specified. These means of control are based on the directive of the energy performance of buildings, decided by the EU and to be used in Sweden. Building owners are obliged to declare the actual total energy use in the buildings and also to report some parameters regarding the indoor climate. The main purpose of these regulations is not only to decrease the total energy use. It is also a good source of information about the actual energy performance of the building. This could help the tenants to make decisions about how to decrease their energy costs and visualize their energy habits.

Since the 1970s, many strategies for reducing the energy demand of buildings have been developed. Existing components have been improved and renewable energy systems have been added, usually resulting in extra building costs. Building construction with more airtight windows and airtight building envelope reduces the air exchange by infiltration. This lowers the use of energy for heating the dwellings but can also cause problems with indoor air quality. Increased relative humidity indoors can in worst cases lead to mould growth in the building envelope. Experience shows that in buildings with an airtight construction, draught problems and the use of energy for heating are reduced but the need to install mechanical ventilation becomes obvious to ensure a high indoor air quality (Feist, Schnieders, Dorer & Haas, 2005).

In the passive house concept these experiences are reflected. The idea of developing the passive house concept originally came from Professor Bo Adamson at Lund University. Inspired by building techniques from a study trip in China, he, together with Dr. Wolfgang Feist, developed the passive house concept (Halse, 2005).

### 1.2.3 Definitions

In this thesis, the following definitions and concepts have been used.

**Energy efficiency:** By choosing the best technical equipment and achieving a better balance between investments and running expenses, the most economic energy use can be achieved for essentially the same energy service.

**Reduction of energy use:** Decrease the use of energy, like services and utilities.

**Reduction of CO<sub>2</sub>-emissions:** The atmosphere contains about 0.035 per cent by volume of carbon dioxide, which is approximately 750 thousands of millions tons of carbon. The carbon content increases by approximately 0.4 % every year by human activities, for instance by burning fossil fuels (www.ne.se). This increase is feared to affect the climate. To avoid future problems due to higher temperatures on earth, it is important to reduce the carbon dioxide emissions.

**Primary energy:** The amount of energy consumption on site, plus losses that occur in the transformation, distribution as well as the extraction of energy.

**Passive House:** A well insulated, airtight construction with mechanical ventilation is the basic idea of a Passive House. Building components which are necessary in any case; the building envelope, the windows and the ventilation system, are optimized to reduce the need of energy for space heating to the lowest possible level. Thermal bridges must be avoided, as must infiltration through the building envelope. Detailed planning is necessary to achieve a well functioning passive house of sufficient airtightness. These improvements result in a building that works almost like a thermos. The German Passive House Institute defines a passive house as follows:

*"A Passive House is a building for which thermal comfort (ISO 7730) can be achieved solely by post-heating or post-cooling of the fresh air mass, which is required to fulfil sufficient indoor air quality conditions (DIN 1946) – without a need for recirculated air." (www.passivhaustagung.de)*

To achieve a comfortable indoor climate in such an airtight building it is necessary to use mechanical ventilation. If the construction of the building ensures that the peak load for space heating is less than 10-16 W/m<sup>2</sup> (in Sweden) the ventilation system can also be used for space heating. In the mechanical ventilation unit an air-to-air heat exchanger is used to heat the incoming fresh air with the warm exhaust air. A separate heating system is then no longer required, which yields savings (J. Schnieders, A. Hermelink, 2006). Additional heat is received by passive solar gain, by persons living in the dwellings and from waste heat from household appliances.



The extreme low energy use also provides financial security for the house owner if the energy prices increase (Smeds & Wall, 2007).

The demands for a Mid-European Passive House are that the annual space heating demand should be less than 15 kWh/m<sup>2</sup>a and that the combined primary energy consumption (space heating, domestic hot water and household electricity) must not exceed 120 kWh/m<sup>2</sup>a (www.passiv.de). The requirement for a primary energy demand prevents that the space heating demand is reduced at the expense of large internal gains from electric appliances. This also discourages direct electric heating (Feist et al, 2005).

### 1.3 Object, method and limitations

To gain knowledge about how to make buildings more energy efficient, further research is needed. The goal for the research regarding residential buildings is to reach considerable efficiencies in the specific energy use for space heating, DHW and electricity for communal areas. The contribution regarding technical services is not only to use the most energy efficient products, properly installed to correspond to the outcome needed. Different technical areas like local combustion of biomass, district heating and district cooling, heat pumps, solar heating and consideration of the building as an energy system are also important. It is essential to carry out detailed studies of the possibilities in a Scandinavian perspective. By sensitivity analyses and in-depth studies for different system solutions, limitations regarding climate can be identified and assessments can be made that show how effective and robust a solution is.

The method used in this research is to practically participate in four demonstration projects, which is a good way to gain knowledge about how to build energy efficient buildings. The expected result is to find guiding principles and tools needed for planning passive houses, not only describing project specific solutions but making the system solutions usable for planning in more general terms, and also to study the possibilities and limitations of energy efficient buildings in a Swedish perspective and climate.

The goals regarding energy use in the demonstration buildings for heating and domestic hot water are 25 – 50% of the energy used in similar buildings built according to the current building standards.

The issues in this project concern two areas;

- 1) Implementation of guiding principles for realization of demonstration projects and resource efficient buildings (passive houses).

## 2) Analyses of possibilities and limitations for resource efficient buildings in Swedish climates

Joining as a part of the planning group, advice and help is given to architects, consultants and to the client. In the planning process, general advice and conceptual solutions can be developed. Lack of components, systems and planning aids can be identified.

The building process and the buildings should be analyzed and evaluated to facilitate the multiplication of demonstration projects. During the construction of the building projects, the work on the building site is closely followed and participants in the building process are interviewed about their work. Interviews are also made with the tenants after they have been living in the passive houses for a while. Measurements are made when the tenants have moved in regarding actual energy use, use of domestic hot water, indoor temperatures etc.

Feedback about the projects is presented; both regarding positive and negative experiences, so that the concept of energy efficient buildings can be spread and further developed.

The research is a four year project. Now after two years, this licentiate thesis describes the results from early planning and design to final construction. During the last two years, until the PhD examination, more detailed analyses will be carried out and evaluation of the projects will be performed regarding energy performance, comfort and occupancy aspects.

### 1.3.1 Limitations

The focus in this project is the total energy use in buildings. There are no deeper studies of moisture problems, only a brief overview when problems have occurred in the projects. The indoor air quality is not yet measured. No detailed studies are made regarding thermal bridges at this level of the project. LCA and LCC studies are not yet performed.

## 1.4 Earlier experiences of European passive houses

The idea of passive houses was first realized in a house built for four private clients in Darmstadt Kranichstein in Germany in 1990/1991. The building envelope was very airtight,  $n_{50} = 0.22$  ach and had a highly efficient heat exchanger (87%) for the ventilation system. This project was very well monitored and results were documented in great detail ([www.passiv.de](http://www.passiv.de)).

The goals of the project were reached not only in terms of energy efficiency; scientific social research showed a high degree of user satisfaction, air quality measurements proved the benefits of the controlled ventilation system, etc. That was exactly what was needed as the starting point to convince scientists, building experts and potential customers that the passive house worked in real life (Schnieder et al, 2006).

The Passive House concept is not an energy performance standard, but a concept to achieve high indoor thermal comfort conditions at low building costs. To be able to minimize the energy demand for space heating and building costs at the same time, the components in the conventional building have to be simplified. However, this simplification must not deteriorate the thermal comfort or increase the space heating load. When the building envelope is so well insulated that the indoor surface temperatures get close to the indoor air temperature, thermal indoor comfort is achieved without the need to place radiators on external walls and below windows. Space heating can then be provided by the ventilation system alone, distributed with the hygienic air flow rates, anyway needed for a good indoor air quality. Problems frequently associated with air heating do not occur provided that the requirements of the passive house are fulfilled (Feist et al, 2005).

The concept of building passive houses implies knowledge and education of everyone involved in the project, which may cause an additional cost for the first projects. When it has never been tried before it might be considered a risk for the organisation. Experience shows that it is important that the architect is aware of space needed for ventilation pipes, solar shadings, placement for the air-supply unit and sizes and placement of windows early in the project (Feist et al, 2005).

To reduce the energy use in the existing building stock, it is very important to be able to reduce the environmental impact of buildings. To make renovation of existing buildings into passive houses affordable, previous projects show that it is recommended to wait until the buildings need to be renovated in any case. If renovations of facades, entrances, windows, bathrooms etc need to be carried out, the extra costs for making the building energy efficient at the same time will not be that large ([www.passiv.de](http://www.passiv.de)).

There are other concepts apart from passive houses for energy efficient buildings, like the Swiss standards “Minergie”, “Minenergie -P” and “Minenergie-Eco” ([www.minergie.ch](http://www.minergie.ch)) and the German standards “Niedrigenergie”, “7-liter haus”, “4-liter-haus etc”.

Now, buildings that comply with the passive house regulations are rapidly spreading across Austria, Germany and Switzerland. In January 2004, in Germany alone more than 4000 dwelling units have been built as passive houses. At present, the concept has extended to other building

categories like office buildings and school buildings and is increasingly applied in building rehabilitation.

#### 1.4.1 Building envelope

Passive House constructions used in Central Europe can not be assumed to work unconditionally in other parts of the world. It is important to develop passive house solutions for each location, suitable for the actual climate and geographic conditions. Local building traditions as well as national/local building regulations must also be considered.

Prefabrication of building elements offers both a potential for cost reduction and allows for improved quality control. Passive Houses are rather similar in construction to standard buildings and no special construction type is required. A minimization of thermal bridges is kept for all constructions. To reduce the peak load on the heating system and to eliminate cold down draught, well insulated doors and windows need to be used.

By placing windows in an optimal orientation of the dwelling (windows facing south) maximal advantage can be achieved from passive solar gains. However, for Swedish climates the solar gains are limited during the very short heating season of Passive Houses. Well dimensioned south window overhangs let the winter sun enter the building while the sun during the summer is shaded to avoid overheating. During spring and autumn vertical shadings outside south windows are more efficient and for windows facing east or west, vertical shading devices are always essential since horizontal overhangs do not cut off the radiation at lower angles.

An overhang such as a roof could also decrease external condensation on the window pane.

#### 1.4.2 Air leakage

According to the German passive house definition, the air leakage through the building envelope should be below 0.6 air changes per hour (ach) by a pressurisation of 50 Pa, resulting in approximately 0.05 ach infiltration rate under normal pressure conditions ([www.passiv.de](http://www.passiv.de)). Studies have shown that a higher level of air leakage through the external building envelope may cause damage by warm, humid air that penetrates the building construction and might cause condensation. A high level of airtightness is also important to keep a uniform indoor temperature. Furthermore, high infiltration rates will lead to an increase in air that does not pass through the heat exchanger of the ventilation system, causing additional need for space heating.

### 1.4.3 U-values

The mean value of opaque building envelopes in Swedish passive houses is usually about  $0.1 \text{ W/m}^2\text{K}$ . In Mid-European passive houses, the U-value of the opaque building envelope parts (walls, roof and floor) needs to be below  $0.15 \text{ W/m}^2\text{K}$ . The use of highly insulating material is necessary. For example, to reach a U-value of  $0.13 \text{ W/m}^2\text{K}$  for the outer wall you will need 15.8 metres of concrete with a thermal conductivity of  $2.1 \text{ W/mK}$  or 6 metres of solid brick with a thermal conductivity of  $0.8 \text{ W/mK}$  (Hastings, 2004). U-values required for passive houses can only be achieved by using really good insulating materials.

The advantages of windows with low U-values are not only reduced heat losses. The windows used in passive houses have comfortable interior surface temperatures even in cold outdoor conditions. This improves the comfort experienced by occupants. A window with a U-value of less than  $0.8 \text{ W/m}^2\text{K}$  has, in Middle European climate, proved to ensure occupancy comfort directly in front of the window, necessary when no radiator is mounted (Schnieders, 2003).

Correct installation of the windows is necessary to reduce the thermal bridges to a minimum. If the windows are positioned within the insulation plane on the thermal envelope and that insulation overlaps the window frame as much as possible, the thermal bridge loss coefficient of installation can be zero. Otherwise, the overall U-value may increase by up to 50% (Schnieders, 2003).

### 1.4.4 Ventilation

The primary function of the ventilation system is to maintain excellent indoor air quality. The ventilation rates are determined according to national indoor air quality regulations. The German passive house guidelines recommend a supply flow rate of  $30 \text{ m}^3/\text{h}$  per person ( $8.5 \text{ l/s}$ , person) and the system should also allow for a minimum air supply setting for times with no occupancy, with a corresponding air flow rate of  $0.2 \text{ h}^{-1}$ . The cross sections of the ducts are chosen so that air velocities are lower than  $3 \text{ m/s}$ . In Sweden the regulations specify  $0.35 \text{ l/s, m}^2$  for comfort ventilation. As in any building, it is important to arrange the supply and exhaust air openings in a way that avoids short circuits.

The balanced mechanical ventilation system supplies air according to national requirements for a good indoor air quality, in Mid-European countries typically  $0.3 - 0.4 \text{ ach}$  (Schnieders & Hermelink, 2006). In Swedish passive houses typical air flow rates are about  $0.5 \text{ ach}$ . When a ventilation heat exchanger is used, the temperature of the supply air

delivered to the living area is preheated by the exhaust air, which helps to keep a comfortable indoor temperature. The heat exchangers should have an efficiency of at least 80% to minimize the ventilation losses.

The maximum temperature of the supply air should be about 52°C. If the heating load in the room exceeds the limit of heating by air, an additional heating system is needed for peak power supply, for instance a small radiator mounted on an interior wall of a room (Feist et al, 2005).

The unit also needs to be very quiet and it should be easy to change filters. The unit must be easy to clean and the energy use for the fans in the unit must be low.

Furthermore, the ventilation system has to be equipped with a bypass of the heat exchanger to keep the indoor temperature low in the summer. Depending on what is most suitable for each specific building project, the ventilation unit in an apartment building can be placed as small separate units in each apartment or as one central unit, placed for instance in the attic, which supplies the whole building. To make sure that heat losses from the ventilation system are low and there is no air leakage from the duct system, it is important that the ducts are carefully insulated. Uninsulated ducts could also cause a thermal bridge carrying cold outdoor air through the heated area on its way to the heat exchanger and the supply air device.

An additional opportunity to increase the efficiency of the ventilation system is the use of buried ducts, often used in Middle European passive house projects. The ground during winter has a higher temperature than outdoor air, and during the summer a lower temperature than outdoor air. It is therefore possible to preheat fresh air in a buried duct during winter and cool the air in the summer. This can be done directly with air ducts in the ground or indirectly with brine circulating in buried pipes and heating or cooling the air with a water-to-air heat exchanger ([www.passiv.de](http://www.passiv.de)).

The additional heat needed for the ventilation system can be supplied by a connection to a hot water coil. The heat in the waterborne heating system can be supplied in many different ways; via the condenser of an exhaust air heat pump, by district heating, by a pellets system or a solar system. Direct electric heating is also possible; however this is associated with a high primary energy demand.

#### 1.4.5 Space heating

The heating demand is largely reduced in a Passive House, and the extra cost for using renewable energy sources to cover a larger part of the total energy demand is lower than in standard houses. Current practice for the Passive House standard is to reduce the final energy demand by the yield of

a solar thermal system (Feist et al, 2005). The solar system can be connected to the supply air heating system and for heating domestic hot water.

The required indoor temperature is approximately the same day and night. If the supply air temperature is set back during night, a marginal amount of energy is saved. If the temperature in the end house in a row is set back during night from 20°C to 18°C when the outdoor temperature is -10°C, it would save less than ½ kWh (Hastings, 2004). The temperature fluctuates slowly in passive houses because of the high insulation levels and the heat recovery of the ventilation. This explains why such houses cool down very slowly.

As the heating load is low, heat transfer via transmission losses through internal walls has been shown to play an important role according to heat transfer in the buildings, besides the heat transfer via mechanical ventilation. A temperature difference of 1K between two rooms can result in a heat transfer between the rooms of approximately 10 – 20 W through a wall of 10 m<sup>2</sup>. It might be hard to achieve different temperatures between rooms if desired (Feist et al, 2005).

The energy use, particularly for space heating, can be higher during the first heating season than later during the continuous operation. This is generally known in the building sector and is caused by additional energy used for structural drying and could also be caused by final building work that is still in progress. It also takes a while before the building service systems are working properly, the mechanical ventilation unit for instance. Furthermore, depending on the usability and complexity of the systems, the phase when the occupants are learning how the system works could take more or less time.

Experiences from Germany show that if occupation starts in winter; heating the cooled down building components for the first time can consume up to ca 3 kWh/m<sup>2</sup> alone. Occupants typically set temperatures between 21°C and 22°C. It has been observed that when the insulation standard is improved, the indoor temperature gets higher. It implies that if the improved comfort is technically realizable at low cost, it is also desired (Schnieders, 2003). Measurements show clearly that summer temperatures in passive houses can be kept in a comfortable range. The even temperature distribution throughout the space with no temperature stratification is experienced as highly pleasant (Schnieders et al, 2006).

People are used to having a “heat source” in the room, mostly a radiator. The air heating system denies the possibilities to turn up the heat on the radiator, which maybe would be nice on a cloudy day in November. The absence of this additional radiant heating might give the tenants a reservation about air heating. A wood stove could compensate for this need of radiant heating. Standard solutions for the integration of wood stoves into passive houses do not yet exist and need to be carefully planned in each



project. Heat radiated and convected from the stove can quickly exceed the heating demand of the room where it is located, causing overheating. The heating power in the stove needs to be low (i.e. 1 - 3kW) so as not to cause too high indoor temperatures. Only a few stoves with this required low heating power are available on the market (Feist et al, 2005). If a wood stove is desired, it is important to balance the ventilation system correctly to avoid the case of an underpressure in the room drawing out flue gases. The wood stove must have a separate air supply and the heat should be extracted from the stove via a heat exchanger. The heat can be used for heating other rooms or for heating domestic hot water (Haas 2007).

#### 1.4.6 The CEPHEUS project

To create the conditions for a broad market introduction of passive houses, the European Passive House project CEPHEUS, "Cost efficient Passive Houses as European Standards", was founded. Within this CEPHEUS project, buildings complying with the Passive House standard were tried out in several European projects; 221 housing units were built in five European countries. The building projects participating in this task were closely evaluated; both regarding technical issues like energy use and use of domestic hot water but also user behaviour under real conditions were studied. The CEPHEUS project was running between the years 1998-2001.

The U-values of the exterior building elements in the dwellings in the CEPHEUS project generally range between 0.1 and 0.15 W/m<sup>2</sup>K. They follow the Passive House standard with a maximum n<sub>50</sub>-value of 0.6 h<sup>-1</sup>. Typical measured air change rates of the mechanical ventilation are about 0.25 to 0.4 ach at normal pressure conditions. The supply air is heated to ca 52°C when required (Feist et al, 2005).

The results from the CEPHEUS projects show that in all projects extremely low levels of primary energy consumption were achieved. Compared to conventional new buildings, final and primary energy savings of more than 50% were achieved, especially the levels of primary energy consumption were extremely low. Household electricity use turned out to have particular importance for primary energy use and could be further reduced (Feist et al, 2005). The passive solar gains were also studied. Through glazing, sized to provide sufficient daylight, passive solar gains can be used to cover one third of the minimized heat demand of the house. The average energy use for domestic hot water was 25 litres per person a day at 60°C, in the CEPHEUS projects (Schnieders et al, 2006). Interviews with the tenants in the buildings showed that thermal comfort was good to very good, both in one-family houses and in apartments.



In most CEPHEUS-projects it was not possible to reduce the overall costs of building services. In total, the extra investment for construction and engineering systems was found to be between 0 and 17% of the pure construction cost (Schnieders, 2003). On average over 12 projects, the specific extra investment cost was 91 €/m<sup>2</sup> or 8% of the total building costs. The additional investment costs of the passive house standard may be expected to decrease significantly in the future. Thermal insulation is already relatively inexpensive, whilst suitable windows and high efficiency ventilation systems make up most of the additional costs (Schnieders et al, 2006).

#### 1.4.7 PEP: Promotion of European Passive Houses

Eight European countries participated in the project PEP: Promotion of European Passive Houses that was finished in May 2006. The aim of this project was to document practical solutions for passive houses in different regions and climates and document the energy saving potential of the passive house concept throughout Europe. Also a preparation for an international certification scheme for Passive House certification was compiled; this in relation to national energy performance certification schemes and the European Performance Building Directive (EPDB).

In all participating projects the German passive house standard for air leakage of  $n_{50} \leq 0.6$  ach was followed, and the ventilated air rate was  $\geq 0.4$  ach or 30 m<sup>3</sup>/pers.h (or the national requirement if that is higher). The most common solution for heating the buildings is to use heated supply air in the ventilation system. The advantage of post heating ventilation air is that no additional heat distribution system is needed. Other heating systems were also used; a radiator mounted in the bathroom, a system of a small bio-gas boiler or solar thermal collectors that supplies central low temperature wall heating. Low temperature heating could also be used in combination with a few radiators connected to a central heating system.

In passive houses involved in PEP, domestic hot water is mainly supplied by solar collectors in combination with another heat source of national common practice, in Middle European countries usually gas.

Local building traditions and lack of building components suitable for passive houses were barriers discovered in the project. Also limited construction skills and limited know-how were barriers for passive houses. Local building traditions can also be a barrier against new constructions and façade materials (Passive House Solutions, Promotion of European Passive Houses 2006).

This project also showed that building projects need to be carefully planned; simple rules of thumb will not do.

## 1.5 Passive houses in Sweden

The first passive house in Sweden was built in 2001, ten years after the first one in Germany. Today in Sweden we have also gained some experience of passive houses in Swedish climates.

The Mid-European demands have been adjusted to be suitable for Swedish climate conditions. A standard has been set up to be used on a voluntary basis when building a passive house in Sweden (Definition av Passivhus, version 1.0, Forum för Energieffektiva byggnader, 2007). At present, the standard is available for residential buildings. In addition to this standard the Swedish regulations BBR should be followed (BBR, 2006).

The heated area referred to in the requirements,  $A_{temp}$ , is defined in the Swedish building regulations; BBR 2006. It is the area of the building inside to inside of the building envelope, which is heated above 10°C (BBR, 2006).

### 1.5.1 Requirements regarding peak load for space heating

The requirements regarding the peak load for space heating in buildings are set to make it possible to use the ventilation system as the heating system at comfort air supply rate.

The supply air temperature should not exceed 52°C, to avoid pyrolysis of dust. If the supply air temperature is more than 52°C it could lead to dust carbonization in the supply air and possibly in or on the supply air ducts, i.e. dust particles would smoulder on hot surfaces and produce undesired smells (Schnieders et al, 2006).

To avoid supply air temperatures above 52°C the peak load for space heating ( $P_{max}$ ) is defined with reference to two climate zones; one for the south climate zone and one for the north climate zone (the definition of zones is according to the Swedish building regulations; BBR 2006). Air is quite a poor heat carrier; at 21°C air has a specific heat capacity of 0.33 Wh/m<sup>3</sup>K.

The peak load for space heating,  $P_{max}$ , should not exceed 10 W/m<sup>2</sup> in the south climate zone and 14 W/m<sup>2</sup> in the north climate zone.

For detached houses of less than 200 m<sup>2</sup>,  $P_{max}$  should not exceed 12 W/m<sup>2</sup> in the south climate zone and 16 W/m<sup>2</sup> in the north climate zone ( $P_{200} = P_{max} + 2 \text{ W/m}^2$ ).

These requirements are based on the following basic conditions that need to be fulfilled;

- The design indoor temperature is 20°C
- The design outdoor temperature is calculated according to Swedish standard SS 024310 regarding DUT<sub>20</sub>.
- The classification of climate zones follows the Swedish regulation BBR 2006.
- Heat gained from household appliances and persons included in the calculations should be maximum 4 W/m<sup>2</sup>
- Solar gains should not be included in the peak load calculation.

Solar gains are not taken into consideration, since the peak load occurs in the winter and during night time when solar gains are insignificant.

### 1.5.2 Maximum power to be used in the ventilation air heating

As a basis for the Swedish Passive House criteria, the main criterion is that it should be possible to heat the house by air and by using the normal ventilation rates. Sweden has higher ventilation rates compared to Germany and also a colder climate. The  $P_{\max}$  levels possible for Swedish residential buildings can be calculated by assuming the maximum supply air temperature to be 52°C, according to the following equations:

$$T_{\text{supply air}} = T_{\text{outdoor,dim}} + \eta \cdot (T_{\text{indoor}} - T_{\text{outdoor,dim}})$$

Equation 1.1

$$Q = V \cdot \rho \cdot c_p \cdot (52 - T_{\text{supply air}})$$

Equation 1.2

$$Q = V \cdot \rho \cdot c_p \cdot (52 - (T_{\text{outdoor,dim}} + \eta \cdot (T_{\text{indoor}} - T_{\text{outdoor,dim}})))$$

Equation 1.3

where:

$T_{\text{supply air}}$  = temperature of the supply air after the heat exchanger (°C)

$T_{\text{outdoor,dim}}$  = the coldest outdoor temperature at the specific location (°C)

$T_{\text{indoor}}$  = the indoor temperature (°C)

$\eta$  = efficiency of the heat exchanger (%)

$Q$  = Peak load for space heating (W)

$V$  = Ventilation air rate (l/s, m<sup>2</sup>)

$\rho$  = Density of air (kg/m<sup>3</sup>)

$c_p$  = Heat capacity of air (J/kg,K)

The minimum ventilation air rate per person for comfort ventilation is 0.35 l/s, m<sup>2</sup>, i.e. 1.26 m<sup>3</sup>/h,m<sup>2</sup>. The indoor temperature is set to 20°C. The efficiency of the heat exchanger is set to 80%. The density of air is 1.2 kg/m<sup>3</sup>. The heat capacity of air is 1000 J/kg.K. This gives:

$$Q = 0.35 \cdot 10^{-3} \cdot 1.2 \cdot 1000 \cdot (52 - (-16 + 0.8 \cdot (20 - (-16)))) = 16.4 \text{ W/m}^2$$

Equation 1.4

If the maximum supply air temperature is 52°C the maximum power is calculated to 16.4 W/m<sup>2</sup> if the design outdoor temperature is -16°C. Thus, this is the limit of using the ventilation system to heat the building. This limit is then used fully for a single-family house in the north climate zone.

The ventilation system does not need to be the heating system, but since the ventilation system is needed anyway, this solution is financially favourable. Other heating systems can naturally be used in combination with mechanical ventilation.

### 1.5.3 Energy demand

The required energy demand includes space heating demand, domestic hot water demand and electricity for mechanical systems (such as fans and pumps). Thus, household electricity is excluded. The energy requirements are set for the south and north climate zones. The energy demands are only recommended in this first Swedish Passive House standard. After evaluation of a number of demonstration projects, the energy demand level should be evaluated and made into a requirement in the criteria.

The maximum amount of bought energy for the building  $E_{\max}$  (excluding household electricity) is recommended not to exceed 45 kWh/m<sup>2</sup>a in the south climate zone and 55 kWh/m<sup>2</sup>a in the north climate zone.

For detached houses of less than 200 m<sup>2</sup>,  $E_{200}$  is recommended not to exceed 55 kWh/m<sup>2</sup>a in the south climate zone and 65 kWh/m<sup>2</sup>a in the north climate zone. ( $E_{200} = E_{\max} + 10 \text{ kWh/m}^2\text{a}$ ).

The following basic conditions need to be fulfilled;

- The design indoor temperature is 20°C
- The energy demand should be calculated with a calculation programme that at least fulfils the requirements in the international standard ISO 13790:2004.
- The classification of climate zones follows the Swedish regulation BBR 2006.

- Heat gained from household appliances and people included in the calculations should be maximum  $4 \text{ W/m}^2$
- Useful solar gains should be calculated by a verified calculation method.

#### 1.5.4 Domestic hot water

A standardized domestic hot water demand is assumed when calculating the energy use for domestic hot water. The yearly use of domestic hot water,  $V_{vv}$ , in  $\text{m}^3$  is assumed to be  $12 \text{ m}^3$  per apartment +  $18 \text{ m}^3$  per person.

In detached houses and terrace houses, the use of domestic hot water,  $V_{vv}$ , is assumed to be  $16 \text{ m}^3$  per person.

The energy use for domestic hot water heating is assumed to be  $55 \text{ kWh/m}^3$ , which means that the total energy demand for domestic hot water,  $E_{vv}$ , is:

$$E_{vv} = \frac{V_{vv} \cdot 55}{A_{temp}} \text{ (kWh/m}^2\text{a)} \quad \text{Equation 1.5}$$

If efficient water saving taps are installed, the person based domestic hot water use could be assumed 20% lower.

The number of persons in apartments is based on the number of rooms and assumed according to Table 1.1.

Table 1.1 Number of persons assumed in apartments as a basis for calculating the energy use for domestic hot water.

Number of rooms	Number of occupants
1 room and a kitchen	1.0
2 rooms and a kitchen	1.5
3 rooms and a kitchen	2.0
4 rooms and a kitchen	3.0
5 rooms and a kitchen	3.5

For detached single-family houses, three persons are assumed when the house is smaller than  $120 \text{ m}^2$  and four persons are assumed when the house is larger than  $120 \text{ m}^2$ .

### 1.5.5 Building requirements

A few requirements on the building envelope are set up to make sure that the building functions as a passive house.

The air leakage through the building envelope should not exceed 0.3 l/s, m<sup>2</sup> at ±50 Pa, measured according to the Swedish standard SS EN 138 29.

The windows should have a total U-value (including frame) less than or equal to 0.9 W/m<sup>2</sup>K measured for a typical window size, e.g. 1200 mm × 1200 mm. The U-value should be measured according to the Swedish standard SS-EN 12567-2 by an accredited laboratory. U-values for other sizes could be calculated according to the standard SS-EN ISO 10077-2. The average U-value for all the windows and glazed areas (also doors with glazing) in the building should be less than or equal to 0.9 W/m<sup>2</sup>K.

It is important that the window area is optimized to avoid too high indoor temperatures in the summer, to avoid discomfort due to low surface temperatures and cold down draughts and to avoid a high space heating demand during the heating season.

### 1.5.6 Sound

Sound from the ventilation system must not exceed the Swedish class B according to the Swedish standard SS 02 52 67.

### 1.5.7 Supply air temperature

The supply air that has passed the heating battery should not exceed 52°C in each supply air device.

### 1.5.8 Measurements

To verify the energy use in the building, it must be possible for the household electricity, electricity for mechanical systems and energy used for domestic hot water and space heating to be read off separately every month. Also, the amount of water used for domestic hot water should be measured. In this connection, the number of persons living in the building must be noted and taken into consideration, to be able to compare different projects.

### 1.5.9 Household appliances

White goods used in buildings should be of Energy class A or better. Low-energy lighting appliances should be used. It is important to keep the use of household electricity low, both to decrease the total use of electricity, but also to avoid too high indoor temperatures or the creation of a cooling demand.

## 1.6 Earlier experiences of Swedish Passive House Projects

The development of components needed for energy efficient buildings is in progress in Sweden, like energy efficient windows and heat recovery systems, and, together with the knowledge about building well insulated and airtight buildings, has made it possible to build passive houses in Sweden (Sandberg, 2003.)

### 1.6.1 The Lindås project

As a part of the CEPHEUS project, the first Swedish passive houses were built in Lindås outside Gothenburg. These 20 terrace houses were built as a result of a demonstration project extending over four years, carried out within cooperation by Efem Architects in Gothenburg, Energy and Building Design at Lund University, Chalmers University of Technology and the Swedish National Testing and Research institute, SP. The 20 units are in four rows of two storeys where each unit has a living area of 120 m<sup>2</sup> or 124 m<sup>2</sup> at the end units.

The strategy when designing these terrace houses was to minimize transmission and ventilation losses and use solar energy for domestic hot water, and at the same time to achieve high comfort for the tenants. Each house has its own ventilation unit with an air-to-air heat exchanger with an efficiency of 80%. The space heating demand is covered by electric resistance heating in the supply air, 900 W per unit. Solar collectors of 5 m<sup>2</sup> per unit provide the energy for approximately 40% of the domestic hot water demand.

The mean U-value of the building envelope including windows is 0.16 W/m<sup>2</sup> K.

Table 1.2 U-values of the building envelope in Lindås (Wall, 2006).

Building envelope	U-value (W/m <sup>2</sup> K)
Ground floor	0.11
Exterior walls	0.10
Roof	0.08
Windows, average	0.85
Door	0.80

Like all CEPHEUS projects the houses in Lindås were closely evaluated both regarding technical issues and in interviews with the tenants. Experiences from Lindås have later been used in subsequent Swedish passive house projects.

The average airtightness at 50 Pa was measured as 0.3 l/s, m<sup>2</sup>. The variation in the energy use between the 20 units is large but not exceptional. The total delivered energy for heating, domestic hot water and household electricity varies between 45 and 97 kWh/m<sup>2</sup>a for different households. The average delivered energy demand is 68 kWh/m<sup>2</sup>a (Wall, 2006).

Studies show that the area of the solar collectors should have been more optimized and the storage tank should have been better insulated, to achieve a higher efficiency in the solar system (Boström et al, 2003).

In the interviews with the tenants in the Lindås houses, it was shown that it is important to give the tenants clear information about how the ventilation system works. Most of the tenants said that they wanted to have an indoor temperature of 20 - 21°C (Boström et al, 2003). The measured average indoor temperature during the heating season was approximately 23°C (Ruud & Lundin, 2004). In the interviews a few of the occupants said that the heating battery was not enough for keeping the indoor temperature as high as wanted; they asked for a fireplace and some tenants had bought electrical radiators as additional heat. The heating battery must not impose limitations if the tenants want a higher indoor temperature. But if the tenants know how to use the ventilation system properly and know how to set the heat on or off, the indoor temperature could be controlled and the battery should be enough to keep the indoor temperature at a pleasant level. The installed power is only 8 W/m<sup>2</sup> and especially the end units could need a 1200 W battery (equals 10 W/m<sup>2</sup>) for the colder periods (Wall, 2006).



### 1.6.2 Glumslöv

The second passive house project in Sweden is located in Glumslöv, Landskrona in the south of Sweden. 35 rental apartments were built in 2003-2004 and the size of the apartments varies from one to four bedrooms. The goal of the project, apart from building well functioning and sustainable passive houses, was to keep the rental cost for the apartment at a maximum of 100 €/m<sup>2</sup>. Each apartment has its own air-to-air ventilation unit with a heat exchanger with high efficiency. During the first winter, the apartments were too cold because the heat exchangers did not meet the required heat recovery efficiency. The company delivering the heat exchangers said that their product had the required efficiency but this was found incorrect in reality. Therefore, all the heat exchangers had to be changed to that used in the Lindås project. This shows the importance of demanding reliable performance data for components and systems, measured by an accredited and objective laboratory.

Both domestic hot water and additional heat to the supply air are covered by electricity. The glazed area corresponds to approximately 20% of the floor area and the calculated total energy demand is 50 – 60 kWh/m<sup>2</sup>a. There is a roof overhang of one metre to limit the solar gains. No monitoring data is available and this project has not been evaluated.

Table 1.3 U-values of the building envelope in Glumslöv (<http://www.iea-shc.org/task28/index.html>).

Building envelope	U-value (W/m <sup>2</sup> K)
Floor	0.1
External walls	0.1
External roof	0.08
Windows	0.9 – 1.0

The vapour barrier in the construction is placed 70 mm into the wall, to make sure it will not be penetrated during the building process or later by tenants. The measured airtightness was 0.1 l/m<sup>2</sup>,s at 50 Pa. The goal for the rental cost is reached and is just below 100 €/m<sup>2</sup> (<http://www.iea-shc.org/task28/index.html>).



## 2 Introduction to the demonstration projects

In this research project four different demonstration projects are studied. These building projects are located in the south-west of Sweden. In these projects we participate in the planning process and work together with the contractors; giving advice and supplying experiences from other passive house projects. Three of the projects are new constructions and one is a renovation project.

### 2.1 Oxtorget – Värnamo

At Oxtorget in the centre of the town Värnamo, five multifamily houses were built with passive house standard, see Figure 2.1. The client Finnvedsbostäder is the public housing company in Värnamo. The main participants in the project are listed in Table 2.1. The five houses consist of 40 rental apartments in 2.5 storeys with apartments with 2 to 5 rooms (Figure 2.2). The tenants moved in during June – July 2006.



*Figure 2.1 Oxtorget, Värnamo.*

Table 2.1 Participants in the project.

**Design team:**

Architect	Karin Arvidsson BSV Värnamo
Structural engineer	Ing-Marie Gustafsson BSV Värnamo
Electricity consultant	BLMB elteknik ,Ljungby
HVAC consultant	FLK Växjö
Measurements	Skanska Inneklimat / Finnvedsbostäder
Advice and evaluation	Hans Eek, Svein Ruud, Eje Sandberg, Maria Wall, the Swedish Energy Agency

**Team of contractors:**

General contractor	NCC
Ground work	Säleby Mark
Plumbing	Jocknicks rör
Electricity	Diö el
Ventilation	Skanska Inneklimat

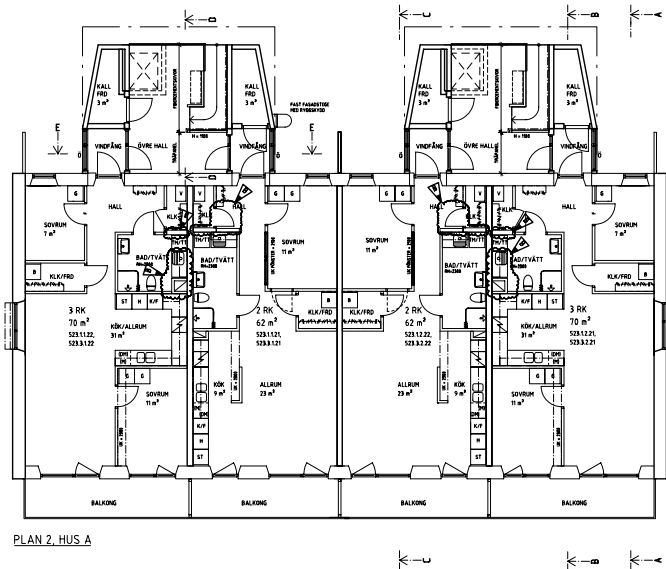

Figure 2.2 Floor plans of the apartments at Oxtorget (bsv arkitekter, Värnamo)

The loadbearing structure is made of concrete and cast on site (Figure 2.3). The external wooden frame walls are also put together on site. The building envelope is highly insulated, see Table 2.2. The construction work

was repeatedly tested to make sure that the air leakage through the walls did not exceed 0.2 l/s, m<sup>2</sup> at 50 Pa.



Figure 2.3 Concrete inner walls cast on site.

Table 2.2 U-values

Building envelope	U-value [W/m <sup>2</sup> K]
Ground floor (excl. ground)	0.09
Exterior walls	0.10
Roof	0.07
Windows, average	0.94
Entry door	0.60

Every apartment has its own small ventilation system with an air-to-air heat exchanger. Additional heat is supplied by electric resistance heating in the supply air.

An active solar system was installed on the roof, 25 m<sup>2</sup> on each building with an estimated solar fraction of 50% (Figure 2.4). An electric heating battery gives additional heat when the solar system is unable to meet the domestic hot water demand.



*Figure 2.4 Solar collectors on the roof*

## 2.2 Karl Johans väg – Frillesås

In Frillesås, south of Kungälv at the west coast, three multifamily houses were built by the client Eksta Bostads AB that is the public housing company in Kungälv. The main participants in the project are listed in Table 2.3. The houses contain 12 rental apartments in two storeys, see Figure 2.5. The apartments have two, three or four rooms (Figure 2.6). The tenants moved in during December 2006.



Figure 2.5 The apartment buildings in Frillesås.



Figure 2.6 Floor plans of the apartments in Frillesås (efem arkitekter, Göteborg).

Table 2.3 Participants.

**Design team:**

Architect	efem arkitekter/ arkitekt Hans Eek
Structural engineer	WSP Byggprojektering
Electricity consultant	El-teknik BA Johansson AB
HVAC consultant	Andersson och Hultmark AB
Measurements	SP Technical Research Institute of Sweden
Advice and evaluation	Lund University, Energy and Building Design

**Team of contractors:**

General contractor	Sätåla Bygg
Ground work	Trädgårdsanläggningar AB
Plumbing	NVS Installation AB
Electricity	Elektro-Emanuel AB
Ventilation	Energiteknik i Mark AB
Metalwork	Fjärås Mekaniska AB
Sheetmetal work	Boplåt AB
Painting	Väst kustMålarna AB
Tiling	MTB Plattsättning AB

The buildings have a loadbearing structure with a well insulated wooden and steel beam construction (Figure 2.7). The external walls are a prefabricated wooden construction, insulated with polystyrene on site (Figure 2.8). The U-values of the building envelope are shown in Table 2.4. The air leakage through the walls did not exceed 0.2 l/s, m<sup>2</sup> at 50Pa. Figure 2.9 shows parts of the equipment used during the pressurization test.





*Figure 2.7 Loadbearing construction. Figure 2.8 External walls.*



*Figure 2.9 Measurement of air leakage.*

Table 2.4 U-values

Building envelope	U-value [W/m <sup>2</sup> K]
Ground floor (excl. ground)	0.11
Exterior walls	0.11
Roof	0.08
Windows, average	0.85
Entry door	1.00

Each apartment has a separate small ventilation system with an air-to-air heat exchanger. The heating battery in the heat exchanger is connected to the district heating system. To ensure high comfort in the bathrooms there is a small heating coil installed in the floor in every bathroom.

The domestic hot water is heated by an active solar system, placed on the roof on the apparatus building (Figure 2.10). Additional domestic hot water is supplied by district heating.



Figure 2.10 Solar collectors on the roof of the apparatus building

## 2.3 Villa Malmborg – Lidköping

The first single-family detached passive house in Sweden was built in Lidköping close to Lake Vänern, by the housing company Vårgårdahus (Figure 2.11). The house is in two storeys with a total living area of 170 m<sup>2</sup>, see Figure 2.12. The family moved in during April 2007.

The loadbearing construction of the house is made of highly insulated prefabricated wooden frame walls (Figure 2.13). It is heated by a small air-to-air heat exchanger with additional heat from district heating. Domestic hot water is supplied by district heating.



*Figure 2.11*     *Villa Malmborg*

Table 2.5 Participants in the project.

**Design team:**

Architect	Hans Knutsson/ Hans Eek
Structural engineer	Vårgårdahus
Electricity consultant	Picon Teknikkonsult AB
HVAC consultant	Bo Lökken AB
Measurements	SP Technical Research Institute of Sweden
Advice and evaluation	Lund University, Energy and Building Design

**Team of contractors:**

General contractor	Vårgårdahus
Ground work	Fridhems bygg
Plumbing	Widells rör och konsult AB
Electricity	Vinninga El
Ventilation	Fridhems bygg

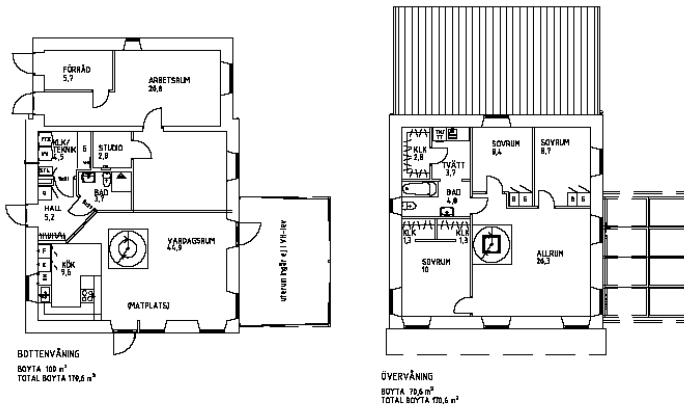

Figure 2.12 Floor plan, Villa Malmberg (Vårgårdahus).



Figure 2.13 Wooden frame construction.

Table 2.6 U-values.

Building envelope	U-value [W/m <sup>2</sup> K]
Ground floor (excl. ground)	0.10
Exterior walls	0.09
Roof	0.07
Windows, average	0.85
Entry door	1.0

## 2.4 Brogården – Alingsås

Alingsåshem, the public housing company in Alingsås owns about 3000 apartments in Alingsås and the surrounding communities. The apartments are continuously renovated according to their need and the next renovation project is 300 apartments in the Brogården area (Figure 2.14).



*Figure 2.14 The Brogården area.*

The apartments in Brogården were built in 1970 and are in great need of renovation. The brick façade is worn out, (Figure 2.15) the ventilation is not working satisfactorily and the apartments are not suitable for elderly or disabled persons.



*Figure 2.15 Worn out brick façade in Brogården*

The tenants complain about draughts and low indoor temperatures. Earlier renovation of similar buildings showed that these complaints did not disappear after the renovation process. When renovating the Brogården area, the buildings need to be made more airtight. They also need to use less energy. The house-owner's capital cost for the houses in the Brogården area is at the same level as the annual energy costs. As a result, the apartments will be renovated aiming for the energy levels of a passive house.

The general manager at Alingsåshem divides the renovation cost into three parts. One part is energy saving, the second is the higher standard in the apartments (larger bathroom, new surface materials etc) and the third is the maintenance cost, the cost for the renovation anyway needed. Since the need of renovation was so extensive, the cost for making the building energy efficient is not dominating.

At first one building with 18 rental apartments will be renovated. The purpose is to learn from this renovation and then use the experiences in the rest of the buildings.

Table 2.7 Participants in the project

**Design team:**

Architect	efem arkitekter/ arkitekt Hans Eek
Structural engineer	WSP Byggprojektering
Electricity consultant	Picon Teknikkonsult AB
HVAC consultant	Andersson och Hultmark AB
Measurements	SP Technical Research Institute of Sweden
Advice and evaluation	Lund University, Energy and Building Design

**Team of contractors:**

General contractor	Skanska
Ground work	Skanska Mark
Plumbing	Alingsås Rör
Electricity	Elteknik EEA AB
Ventilation	Bravida

The building is in three storeys with two stairwells. Three apartments on each floor share a stairwell, see Figure 2.16. The loadbearing structure is made of concrete. The outer walls consist of an insulated wooden beam construction, with brick as the surface material (Figure 2.17).

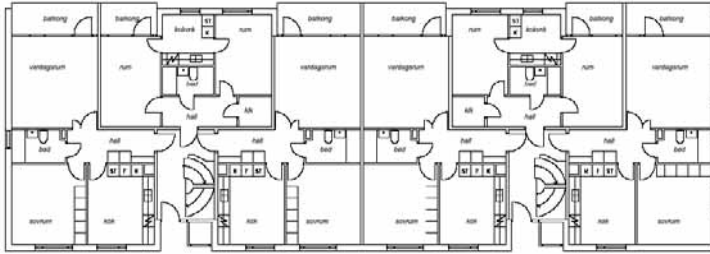

Figure 2.16 Floor plan of the multifamily house at Brogården (efem arkitektkontor).

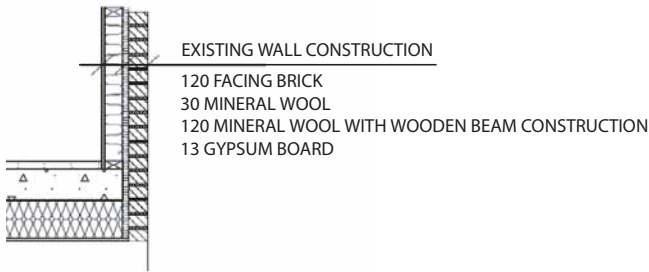

Figure 2.17 Exterior wall before renovation.

Table 2.8 U-values, before renovation.

Building envelope	U-value [W/m <sup>2</sup> K]
Ground floor (excl. ground)	0.38
Exterior walls	0.30
Roof	0.22
Windows, average	2.00
Entry door	2.70

The building has been examined regarding possible moisture problems and air leakage. Even though the brick façade is worn out, there was no trace of moisture in the wooden wall construction and this could then be kept in the renovated building. A new façade material will be chosen, with the same architectural expression as the old brick façade, but able to





The amount of bought energy is measured (2004). Simulations regarding energy use have been made using the new constructions. In the goal for the demonstration building, the solar collectors are assumed to cover 50% of the domestic hot water heating.

Table 2.10 Energy demand, before and after renovation, if the proposed measures will be taken.

Energy Demand [kWh/m <sup>2</sup> a] building	Today: (2004)	Goal: Demonstration
Space Heating	115	30
DHW	30	25
Household Electricity	39	27
Electricity, common area	20	13
Sum	204	95

Today the apartments have an exhaust air ventilation system. When renovated, each apartment will have a separate ventilation system with an air to air heat exchanger. Additional heat is supplied by district heating in the supply air.

During autumn 2007 the planning process in the Brogården project is in progress. The building process, measurements and results will be presented in the final thesis in 2009.

## 3 Apartment buildings in Värnamo, Oxtorget

In the centre of Värnamo (latitude 57°12'12 N), in the southern part of Sweden, 40 rental apartments were built according to the passive house standard as part of the public housing sector. Värnamo is a small town that is slowly growing, and these apartments are a part of the local municipality's plan of expansion. The apartments are built on an old market place called "The Ox Square" (Oxtorget) since the time when the place was used for dealing with cattle.

### 3.1 Decision

Finnvedsbostäder, the company of public housing in Värnamo, were chosen by the municipality to develop the area of Oxtorget. At first the project was planned as regular apartments. When the project was presented to the neighbours living round the square it turned out they did not like the plan of loosing their green space and appealed against the project.

At the same time as the appeal process went on, the staff at Finnvedsbostäder went to a conference where they, among other things, discussed the costs of the maintenance of a building over many years. They discussed how large the running cost of apartments in general is compared to the cost of the actual construction of the buildings. Looking at the small running costs for a passive house, they decided to build the houses at Oxtorget as passive houses. The appeal against the project was taken to the Swedish government, but the neighbours' point of view was not considered.

A working group with the architect, the constructor, the HVAC consultant and the general manager from the client Finnvedsbostäder, started to work on the project, now as a passive house project. Soon they realized that they needed specific criteria for e.g. the energy demand and peak load in order to guarantee a good result. The general manager from Finnvedsbostäder decided that they should use the same criteria levels as

those used in the Lindås project. This resulted in a list of specified requirements for the project.

## 3.2 Basic requirements

The planning group sent an application to the Swedish Energy Agency for a demonstration project. Funding could be granted for extra costs regarding quality assurance during the building process, measurements, evaluation and dissemination but not for any construction costs. In the application, the following requirements regarding the buildings were specified.

U-values:	Windows: 0.85 W/m <sup>2</sup> K Exterior walls: 0.10 W/m <sup>2</sup> K Roof: 0.08 W/m <sup>2</sup> K Floor facing ground: 0.09 W/m <sup>2</sup> K (excluding foundation ) Entry door: 0.6 W/m <sup>2</sup> K
Airtightness:	0.2 l/s, m <sup>2</sup> (leaking area) at 50 Pa
Acoustics:	Swedish Class B, including walls between apartments and floors. This means that, in living rooms or bedrooms, 26 dB(A) is the highest allowed sound level from interior installations and in a kitchen 35 dB(A) is allowed. Noise from outside should not be higher than 26 dB(A) in rooms and 31 dB(A) in kitchens. (SS 02 52 67 utgåva 3, 2004)
Household appliances:	Energy class A++
Air heat exchanger efficiency:	85%
Solar collectors:	Yes, for domestic hot water
Drainage heat exchanger:	Yes

## 3.3 Planning

The general manager of Finnvedsbostäder has been a driving force in convincing people that Oxtorget should be a passive house project. To make

sure that the architect and the constructor would know what a passive house was, he took them for an educational visit to Lindås.

The architect, the structural engineer and the HVAC consultant then continued working with solutions for the passive house constructions. Careful calculations of the construction were made, not only regarding energy aspects, but also to make sure that there will be no problem with condensation in the construction. Detailed descriptions of the HVAC systems were made based on the criteria specified in the application form.

No extra education was given, the HVAC consultant based his work on earlier knowledge and realized that the eye of the needle was to make a well functioning building construction; otherwise the airtightness of the building envelope, and as a consequence the ventilation system, will not be satisfactory. He therefore helped the structural engineer with the concept regarding passive house constructions.

### 3.4 Constructions

The work from the architect and the structural engineer resulted in five buildings; two with two floors and three with 2.5 floors (Figure 3.1). The apartments have two, three, four or five rooms with either a balcony or with a patio on the ground floor (Figure 3.2). The ceiling height is 2.50 m. To distribute the daylight within the apartments, fanlights are placed over the interior doors, between rooms.



Figure 3.1 South east and south west façade of the buildings (bsv arkitekter, Värnamo).

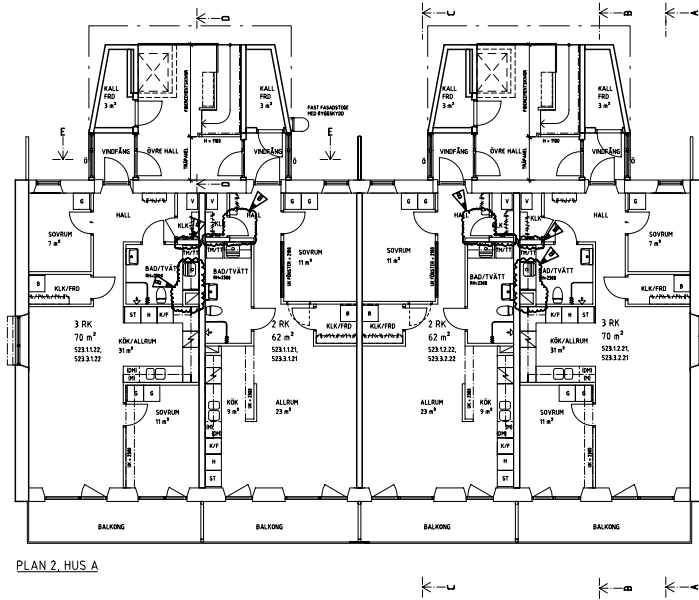

Figure 3.2 Floor plans of the buildings at Oxtorget (bsv arkitekter).

On the bathroom floor there is plastic matting. In the hallway there is a rubber carpet and the rest of the apartment is parquetted. The indoor walls are painted; the tenants can choose wallpaper at their own cost. The white goods used are in energy class A++.

U-values for the building envelope are shown in Table 3.1. The part of the floor facing ground right under the apartment walls has a total U-value of  $0.15 \text{ W/m}^2\text{K}$  excluding foundation .

Table 3.1 U-values of the building envelope parts.

Building envelope	U-value [ $\text{W/m}^2\text{K}$ ]
Ground floor (excl. foundation)	0.09
Exterior walls	0.095
Roof	0.07
Windows, average	0.94
Door	0.60

### 3.4.1 HVAC system

Every apartment has its own mechanical ventilation system with heat recovery. An electric heating battery delivers heat in the supply air during cold days. The unit is placed in a closet to minimize internally generated sound. The power of the battery is 0.9 kW or 1.8 kW depending on the size of the apartment (14.5 W/m<sup>2</sup> – 16.8 W/m<sup>2</sup>). According to the producer, the heat exchanger has an efficiency of 85%. To make sure that no noise will be generated, two silencers are mounted on the supply air system, right after the heat exchanger unit. On the exhaust air duct, one silencer is mounted.

The power supply needed for the two fans in the unit is 58 W for each fan. The unit is running continuously 24 h per day with five different air flow levels of the fans. The exhaust air filter is a EU3 and the outdoor filter EU7. The supply air temperature is adjusted by a sensor in the exhaust air placed in the exhaust air duct. When the tenants leave their apartment, they can press a button for a reduced airflow. If the indoor temperature becomes too low with this reduced flow, the sensor gives a signal to turn up the air flow until the indoor temperature reaches the required level. In the summer, an automatic by-pass function in the ventilation unit supplies the outdoor air into the apartment without passing the heat exchanger. The by-pass function can be blocked. This will be needed if the indoor temperature is getting higher than normal by e.g. a party in the house when the outdoor temperature is low. The heat exchanger unit is automatically defrosted. The ventilation air flow at normal settings is around 30 l/s in the two and three room apartments and 40 l/s and 45 l/s in the four and five room apartments. The exhaust fan in the kitchen is separated from the rest of the ventilation system and is equipped with a timer.

The indoor temperature is planned to be 20°C but can be set higher if required by the tenants. To help the tenants know if their indoor temperature is at 20°C and they are getting a small energy bill, there is a display mounted on the wall, one in each apartment, showing the indoor temperature, see figure 3.3. For higher temperature in the bathrooms, there is an electrically heated towel rail in each bathroom that gives additional heat if needed.



*Figure 3.3 Display showing the temperature in each apartment.*

### 3.4.2 Domestic hot water system

All five buildings have solar collectors on the roof connected to a central room for domestic hot water production, one in each building (Figure 3.4). There are 25 m<sup>2</sup> of solar collectors on each building. The solar fraction is assumed to be 50%. Additional heat for domestic hot water is supplied from an electric battery in the accumulator tank.





Figure 3.4 Solar collectors.

The hot water system consists of two water heaters. When the solar collectors are not in use, cold water is going into water heater 1 and continues into water heater 2. Here, the water is heated to 65°C. Before going out to the tap water system, the heated water is mixed with cold water to 60°C.

When the sun is shining and the sensor on the roof indicates a 3-4°C higher temperature level than the temperature in the first domestic hot water tank, the pumps for the solar system start. Water mixed with glycol circulates and is heat exchanged to the domestic hot water system. The hot water passes to water heater 1 and after that, to heater 2 and is heated to 65°C.

If the temperature of the water is 65°C already when it has been heat exchanged, it will go to heater 2 directly. If the sun shines so much that the temperature of the water exceeds 90°C, the water is drained off. New cold water is added to the system to keep the balance, and is at the same time cooling the system.

The cold water in Värnamo holds a temperature of 5 – 9 °C. To prevent the water from cooling floors and walls, the cold water pipes have additional insulation.

There is no hot water circulation in the apartments. Instead, the cold and hot water pipes are highly insulated to prevent the water temperature from falling or increasing when water runs. The client is very well aware of the problem with legionnaires' disease and has been thinking closely about it when designing this solution. The apartment placed furthest away from the water heater might need to wait for hot water for a while after turning on the tap. If these tenants are the first ones in the morning to turn on the hot water, they might have to wait for approximately 30 sec. for hot water.

### 3.5 Simulations

One of the five buildings in the project was simulated in DEROB-LTH (Kvist, 2006). Derob-LTH is a dynamic simulation program for calculations of energy demands, peak load for space heating, indoor temperatures, surface temperatures etc. In this project the energy demand and the peak load for space heating were calculated. The building is built up by coordinates into a 3-D volume as shown in Figure 3.5. The building in the simulation has a ceiling height of 2.50 m (building type A). The balconies and the store rooms outside the entrances are modelled as solar shadings.

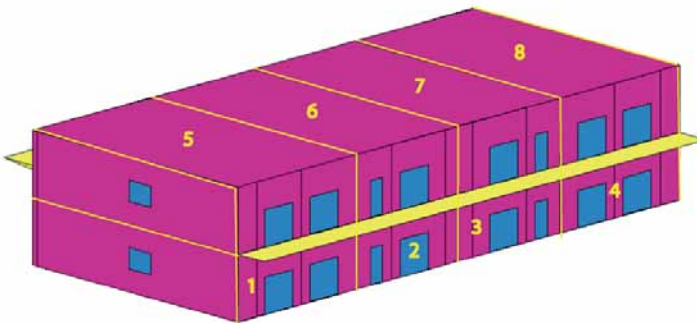

Figure 3.5 The building simulated in DEROB – LTH.

Input data in DEROB-LTH:

Space area: 598 m<sup>2</sup>

U-values:

Floor facing ground: 0.09 W/m<sup>2</sup>K

Outer wall: 0.095 W/m<sup>2</sup>K

Inner wall: 3.3 W/m<sup>2</sup>K

Roof: 0.07 W/m<sup>2</sup>K

Outer door: 0.06 W/m<sup>2</sup>K

Windows: 0.94 W/m<sup>2</sup>K

Ventilation:

Air leakage: 0.05 arch

Mechanical ventilation: 0.5 arch

Efficiency of heat exchanger: 80%

Ventilated volume: 85%

Orientation:

The building is rotated 20 degrees clockwise from south

Soil resistance:

2.64 m<sup>2</sup>K/W

Ground reflection:

20%

Internal gain:

4 W/m<sup>2</sup>

Indoor temperatures:

The indoor temperature is set to 20°C and 22°C respectively.

For the studies of energy demand and peak load the maximum allowed indoor temperature was set to 25°C. Above this temperature, the occupants are assumed to reduce the temperature by using shading devices and/or opening windows.

Climate data:

The simulation is made with climate data for Jönköping

### 3.5.1 Calculated results

With an indoor temperature of 20°C the peak load for space heating is 8.3 W/m<sup>2</sup>. The space heating demand is then calculated to 9.8 kWh/m<sup>2</sup>a.

If the indoor temperature is 22°C the peak load for space heating is calculated to 9.1 W/m<sup>2</sup> and the space heating demand is calculated to 12.8 kWh/m<sup>2</sup>a. The constructions are designed to avoid thermal bridges. Small thermal bridges might anyway occur in the junctions between parts of the construction. Energy demand caused by these thermal bridges is not included in the calculated result.

## 3.6 Tendering

The client invited tenders for the project according to the law of public tendering. Since the specification of requirements was much stricter than in a normal project, many contractors desisted from making an offer. They did not know if they were going to be able to reach the demands aimed for. The required airtightness seemed especially hard to achieve. Finally, only two contractors tendered for the contract.

The large contractor NCC got the all-in – one contract. They did not take the contract in order to build passive houses. They simply wanted to build apartments in Värnamo and they happened to be of passive house standard.

The organisation on site was just like in a regular project. The building company NCC was responsible for engaging the subcontractors. The contractors chosen for the project were experienced and had been working in projects with NCC before, with good results. The law of public purchasing has been used for all the subcontractors.

## 3.7 Planning deviations

Before the contractor started with the construction, they had a discussion with the client, Finnvedsbostäder, about the specification of requirements. This resulted in a few deviations from the original requirements.

### 3.7.1 Heat recovery from sewage water

The heat recovery planned from sewage water was cancelled from the project. It would have been too expensive, mainly because the heat exchanger would require to be placed in a basement under the buildings. There would be no room for a basement just by excavation, the basement needed to be blasted into the ground, which would be very expensive. Also, all heat exchangers for sewage water on the market at the time for purchasing were too large for this application, and would therefore have too low an efficiency to be profitable.

### 3.7.2 Windows

Windows with the required U-value of  $0.85 \text{ W/m}^2\text{K}$  were at the time of purchasing not produced by any Swedish window producer. The U-value

of  $0.85 \text{ W/m}^2\text{K}$  demanded for windows had to be abandoned because it was not possible to produce Dreh-Kipp windows with such low U-value in Sweden. It was important for the client to get Dreh-Kipp windows so the tenants could air the apartments in a good way and also for the tenants to be able to safely leave their apartment with the window in airing position. To ensure a good total U-value for the windows in any case, the number of fixed windows was increased, where the U-value could be lower than the U-value for the operable windows. The mean value of the window purchased in this project was  $0.94 \text{ W/m}^2\text{K}$ .

### 3.7.3 Airtightness

The required airtightness of  $0.2 \text{ l/s m}^2$  seemed hard to achieve for the contractor. Together with the client they decided a new requirement of  $0.4 \text{ l/s m}^2$  with the goal to reach  $0.2 \text{ l/s m}^2$  if possible.

## 3.8 Education

In September 2005, before the major work started on site, everyone involved were gathered for an afternoon of education. The standard of passive houses and the importance of airtightness were discussed. Real models of the wall and roof constructions were placed at the working area and discussed. Pictures of another passive house project in Glumslöv in southern Sweden were shown. Solutions from the contractors in Glumslöv were passed forward. This afternoon of education was much appreciated and made everyone aware of things of special importance when building passive houses. The information was later on passed forward to the subcontractors.

The models of the roof, outer wall and foundation construction were placed on site, see Figure 3.6. The carpenters looked at these together with the drawings before mounting. These models were much appreciated by the contractors.



Figure 3.6 Models of construction.

### 3.9 The construction stage

All walls and system of beams were made to fulfil the Swedish sound class B. To reduce the moisture content in the concrete the apartments were ventilated until the required moisture content of maximum 85% was reached. The concrete used for all constructions has a w/c ratio of 0.6. Additional measurements of the RH content in the concrete construction were performed before the walls were mounted, to ensure that the moisture content was low enough.

#### 3.9.1 Foundation construction

The work on the foundations of the five houses started in August 2005. After excavation, macadam was spread on the bottom. Insulation to stabilize the construction was put on the macadam under the loadbearing plinth. To avoid thermal bridges, two L-elements were put outside the plinth for thermal insulation (Figure 3.7). This gives a high indoor comfort with no risk of cold floors or cold inner walls. On the inside of the plinths, 350 mm of insulation was placed and on top of the insulation a concrete slab of 100 mm was cast on site. The sliding surface between the foundation and the walls separating the apartments was made airtight.

The foundation works were performed during the warm season. Everyone at the construction site agrees that this was very good and made the work run easily.



*Figure 3.7*      *Foundation construction insulation.*

### 3.9.2      Loadbearing structure

The walls in the loadbearing structure were made of concrete and cast on site. After the hardening process of the walls, the work continued with the ceiling/ floor also cast on site, then the walls on the next floor were made and so on. Finally the concrete skeleton was made, see Figure 3.8.



*Figure 3.8 Concrete construction cast on site.*

To reach the U-value that was set in the specification of requirements for the partition walls and the floors, the walls had to be cast twice with insulation in between. This was too expensive and the insulation seemed to be pointless, so this requirement was cancelled.

To cast concrete walls on site was more common about ten years ago. Now, prefabricated concrete is most commonly used. In the planning process additional time was reserved to cover for uncertainties of this casting process. However, the work went very smoothly and the casting took much lesser time than assumed. This saved money as well.

### 3.9.3 Exterior walls

The exterior walls were made of wooden frame construction and mounted on site. From the outside, the walls consist of a façade material, wooden studs with mineral wool, expanded polystyrene, plastic foil and on the inside wooden studs with mineral wool and gypsum board (Figure 3.9).



**REGULAR WALL**  
GYPSUM  
120 mm MIN. WOOL+BEAM  
PLASTIC FOIL  
150 mm CELLULAR PLASTIC  
120 mm MIN WOOL+BEAM  
45 mm MIN WOOL+BEAM

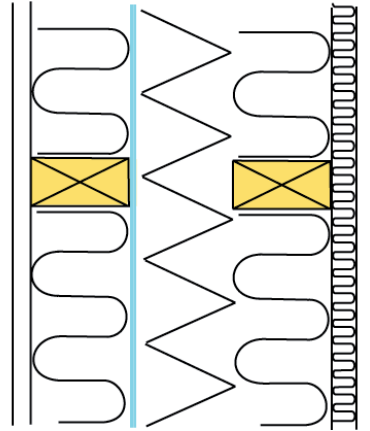

*Figure 3.9 Exterior wall.*

It is important to keep the construction airtight and dry. The place of the plastic foil in this construction makes it easy to avoid damage to the plastic sheet when mounting pipes and electrical equipment, see Figure 3.10.



*Figure 3.10 Space for installation.*

To be able to test the airtightness of every apartment separately, double sided adhesive tape was put between the floors; in the connection with the roof and the connection with the foundation . Making the walls perfectly airtight took extra time as well. The plastic foil in the walls was sealed for each apartment to be able to measure the specific airtightness. During the cold winter there were problems with the tape sealing the plastic, it did not stick to the concrete in the partition walls and to the floor when it got too cold. To make it stick to the concrete, the concrete has to be prepared and this takes time. To solve this, the carpenters have let the plastic foil overlap between the apartments and put the tape on the plastic foil, where it easily sticks even if it is cold outside. It was discussed at the construction site if it would be better to wait with the outer walls until it was warm enough for the tape to stick, but since the winter 2005 was very cold for a long time, this would have caused too long a delay.

To protect the wooden construction from the moisture in the concrete slab, there is a metal sheet placed on the concrete slab that breaks the capillary suction. A small spacer block made of plastic is also put under the wooden beam for additional moisture reduction. The steel strip construction has been tested to make sure it will not cause a thermal bridge (Figure 3.11).

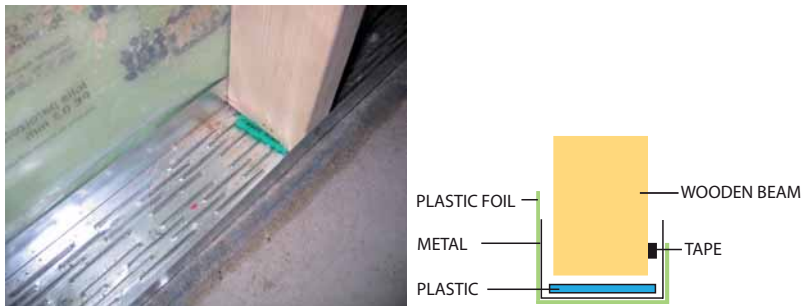
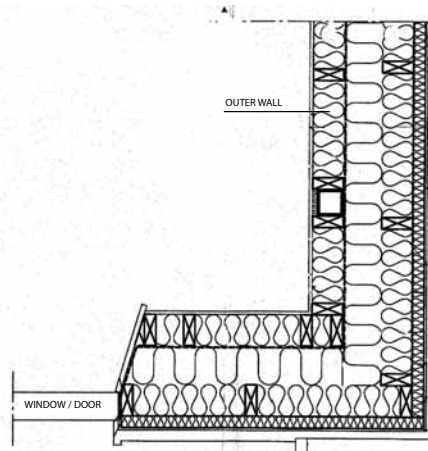

Figure 3.11 Protection of wooden construction.

The projection of the roof protected the carpenters and the building from bad weather. During the cold months, to protect the walls from snow, a tarpaulin was suspended from the roof towards the ground as additional weather protection.

On the initiative of the structural engineer, the moisture content in the walls was checked before they were closed up. This was not a specified demand, but it was done to guarantee the durability of the construction over a long period of time.

To build the walls on site makes it easy to adjust the height of the walls if necessary. When mounting the walls, first the internal wooden frame construction was made, then the plastic foil was mounted on the outside, followed by the polystyrene and the external wooden frame construction (Figure 3.12).



HORIZONTAL SECTION -110-

Figure 3.12 Constructional drawing (bsv arkitekt).

The plastic foil in the outer wall construction was drawn and sealed by two “plastic – teams”. Each team consisted of one very experienced carpenter and one young carpenter. All four of them are known for easily finding a good solution if a problem occurs or making up new solutions for issues never handled before. These double exterior walls take more time to finish than traditional walls and are made standing outdoors; something the carpenters say is irrational. It is especially inconvenient working from the outside when pulling the plastic in front and behind the sills. They think it would have been easier to start making the wall from the outside and to build up the wall towards the inside, as suggested in Figure 3.13.

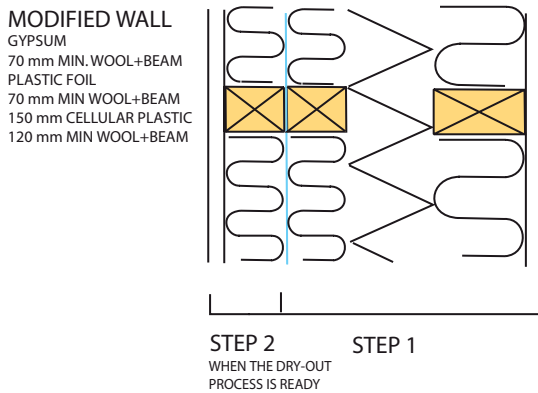

Figure 3.13 Suggested outer wall construction.

The carpenters did not realize that this was a construction with mounting difficulties until they have worked on it for a while. They do not think they would have seen the mounting problems if they had seen the drawings before they started mounting on site.

The thick walls and the position of the windows close to the outside allow the flaring of the deep window cross-section into the room (Figure 3.14). This allows more sunlight and is often seen in old castles. This construction part took time to finish and the carpenters said that to make the building process shorter, the window bays should be straight.



*Figure 3.14* Window bays.

It was hard to find an entry door on the Swedish market that has a U-value of  $0.6 \text{ W/m}^2\text{K}$ . Therefore, the general manager of Finnvedsbostäder made his own door design and produced it at one of the largest Swedish door companies (Figure 3.15). Since the door was quite expensive, the door company supplied a cheap door to use during the building process, which was changed just before the tenants moved in.



*Figure 3.15* Entry door and Per Magnus Rylander, Finnvedsbostäder.

### 3.9.4 Roof construction

The wooden roof construction was mounted on site. They used two different solutions for insulating the roof, depending on the number of storeys of the building. Three of the buildings are in 2.5 storeys. Here, the thermal insulation in the roof construction is mounted on a sheet of particle board, following the roof slope, see Figure 3.16.



*Figure 3.16* Roof in building with 2.5 storeys.

The sheet of particle board ensures that there is an air gap and that the construction is properly ventilated. On the inside of the insulation, facing the room, a plastic foil is mounted. To secure the impenetrability of the plastic foil it is closely sealed with double sided adhesive tape.

The remaining two buildings are in two storeys. Here, the ceiling is horizontal and the loose wool insulation is placed in the attic in a ventilated construction, see Figure 3.17.

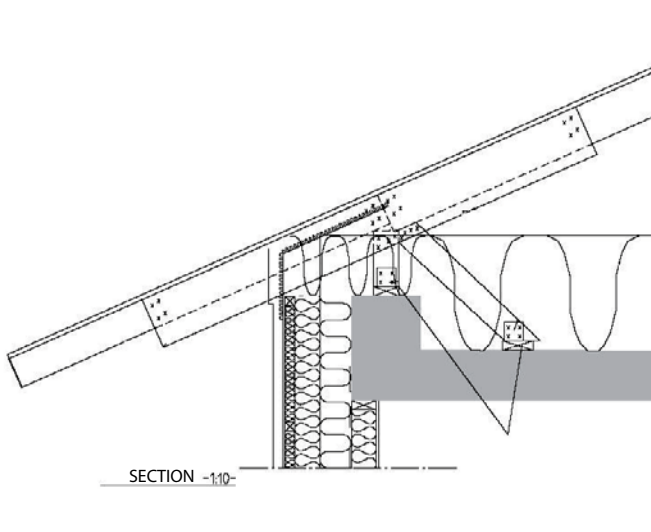

Figure 3.17 Roof in building with two storeys (bsv arkitekter).

### 3.9.5 Ventilation

All apartments have their own air-to-air heat exchanger placed in a walk-in-closet next to the bathroom. To avoid spread of noise from the fans into the rooms through the ventilation system, two silencers are mounted on the supply air duct directly after the heat exchanger unit and one silencer is mounted on the exhaust air duct. The drainage pipe from the heat exchanger is led to the bathroom. Space heating is supplied by an electric heating battery on the supply air side in the heat exchanger unit.

The client had difficulties choosing the ventilation unit. They were choosing between two units that could be suitable for the project. Finally it turned out that for one of the units they were not able to get a by-pass function of the heat exchanger. This was an important demand, not negotiable and then there was no option. The client is not satisfied with the amount of energy that the ventilation unit is using for the fans and would welcome a competition on the market for ventilation units to enable lower energy use for the fans. At full speed, the fans in each apartment use  $2 \times 58 \text{ W}$ , with a lower use of power at lower speeds.



### 3.9.6 Domestic hot water system

The solar collectors were mounted by the plumbers. The panels are partly covered by a metal cover on the roof, placed there for architectural reasons. This has been taken into account according to the efficiency. The sensors mounted on the solar collectors which report when the water heated by the solar collectors is warm enough, are also covered by the metal cover on the roof. To be able to inspect the sensors in the future, the places where the sensors are put, are marked out on the metal cover to be easily found.

The domestic hot water is heated partly by solar radiation and partly by electricity. The choice of an electrical battery instead of a waterborne battery with another heat source was that electricity was needed in the apartments anyway and the total cost for one litre domestic hot water made this way, will be the same as if it was supplied by district heating. An additional connection to district heating would be too expensive. Since the price of electricity has increased dramatically since the planning of the project started, the client says that electricity for heating air and domestic hot water would not be an option if the houses were planned today. The electricity is produced by wind power.

## 3.10 Measurements

### 3.10.1 Airtightness

The contractor was not sure if they would be able to make the building as airtight as stated in the requirements for the project; 0.4 l/s,m<sup>2</sup> at 50 Pa. They had never built this airtight before and it was important to discover in an early phase if they were building with the right method to achieve the airtightness required.

On the initiative of the contractor, one apartment was measured at an early stage when the walls were mounted and holes for doors and windows were covered with plastic, to measure any air leakage in the construction. The measurement was performed by the carpenters, with differential pressure also across the apartments. The measurement showed that air was leaking between the inner walls and the slab. The air was leaking through the expansion joint, but it was easy to seal with a sealant. In a second measurement the results were much better and the contractor now could finish all apartments, having measured values for the specific construction and not only a feeling of doing it right.

The final measurements showed an average air leakage  $0.2 \text{ l/s m}^2$  for all buildings. The area used is the surfaces facing outdoors. No measurements were made without differential pressure across apartments. Thus, the leakage through the building envelope alone is equal to or smaller than  $0.2 \text{ l/s m}^2$  (if the area towards adjacent apartments were completely airtight, all the leaking air would go through the building envelope and thus be equal to  $0.2 \text{ l/s m}^2$ ).

The airtightness differs much between the two roof constructions. One explanation could be that the nails in the roof construction for the buildings with 2.5 storeys are too long for the built space for installation and reach the plastic foil. The gap between the under-roof and the plastic foil is here narrower than the gap between the gypsum and the plastic foil in the walls. The plastic foil in the roof can therefore be perforated by the nails. The plastic in the construction is stapled to the roof truss with a stapler, which also lets through air. These ways of construction can easily be avoided in the future. The plastic foil in the attic was sealed afterwards to increase the airtightness.

### 3.10.2 Sound

Measurement of sound produced by the ventilation unit and transported in the ventilation system has been made in a four room apartment. Results are shown in Table 3.2.

Table 3.2 Measured sound levels in one four room apartment.

Room:	Sound level [dB(A)]
Bedrooms	19, 19, 22.8 and 23
Kitchen	26.9
Bathrooms	31.4 and 34.9
Hallway	35.1

The ventilation unit is placed in a closet close to the entrance of the apartment. To increase the accessibility of the closet, the doorstep between the hallway and the closet is taken away. This can signify some noise leaking from the ventilation unit in to the hallway and explain the higher sound level in the hallway resulting from this.

### 3.10.3 Household measurements

The use of household electricity and domestic hot water is closely measured by the client. Every month the tenants' use of electricity and domestic hot water is shown on the rental notification, together with the cost. This makes it easy for the tenants to have an influence on both the use and the costs of the electricity and domestic hot water. The tenants pay SEK 1.20 / kWh for household electricity; this includes the fixed costs. There is a large cost saving potential for the tenants by reducing the electricity use.

In eight apartments (one of the buildings) the indoor temperature, outdoor temperature, total electricity use and the use of electrical power to the heating battery are also measured by the client. These figures are carefully evaluated by the client to see if the buildings will meet the requirements.

## 3.11 Economy

The calculated total cost for the client was SEK 50 243 000. The purchased total cost was SEK 52 300 000 . The final cost for the client was SEK 55 700 000. The gross amount per square meter, subsidies not subtracted, ended up at SEK 17 898 /m<sup>2</sup>. The total cost for the contractor was SEK 36 700 000, VAT not included; approximately SEK 11 800 /m<sup>2</sup>. In these prices, the cost of the piece of land is included as well as costs for electricity- and water connections. The client estimates that for building a regular house just meeting the building code requirements, the cost would probably be around SEK 15 000 /m<sup>2</sup>. Two years ago, the client built similar apartments, not to passive house standard. The cost of building these apartments was approximately SEK 13 000 /m<sup>2</sup>.

The difference between the cost for the client and the cost for the contractor shows that there is a large cost for the design stage. Since the planning first started with regular houses and then had to be modified to passive houses, the first documents used in the process for building permission had to be drawn up twice. Also more drawings were made, compared to other projects. It was the contractor that ordered drawings and other documents needed for the project. But it was the client who paid for these documents on a running account. Since no one really had control over the number of documents ordered, these extra costs became really high. However, this ordering of documents was really good for the relationship between everyone involved, creating a good dialogue that improved the quality of the project. Different solutions have been discussed between the

contractor, the architect and the structural engineer and if the proposed solution was found not to work properly, another solution was tried. The very detailed planning made the work on site progress smoothly, keeping the additional costs for the contractor low.

The architect and the structural engineer estimated that their costs as far as basic data for tendering documents, including the detailed plan and extra costs for the appeal against the project, were approximately SEK 750 000 . The cost for the analysis of making the buildings into passive houses was estimated to SEK 500 000. Changing the basic data for the tendering documents to a passive house project was an extra cost of approximately SEK 250 000. The total costs for the detailed planning were SEK 1 000 000. The estimated extra costs in the detailed planning, because it was a passive house project, were about SEK 200 000 – 300 000 .

The client estimates that in a traditional project, the costs for planning are usually about SEK 400 000.

More time was used for the contractor than was expected, even though they added 1000 h when they made the tender, compared to a usual project. Especially it took more time than expected to meet the requirements of airtightness. Making the concrete frame work took less time than expected. The general contractor estimated the extra hours needed to be in total around 1000 h, in total 2000 h.

The application for subsidies was for SEK 1 650 000. The project received two financial contributions from the Government. One was for using solar collectors for domestic hot water and the other was a contribution from the Swedish Energy Agency for making this a demonstration project. To manage the extra costs in the project, the board of Finnvedsbostäder has decided to enlarge the depreciation from 40 to 50 years.

### 3.11.1 Specific additional costs

#### Entry doors

The entry doors were a large extra cost in the project. 40 doors cost SEK 250 000 + VAT. The door is 7 cm thick and has a U-value of 0.6 W/m<sup>2</sup>K. The demand for fire safety was not higher than for a regular door. The entry door is estimated to save 200 kWh/year in reduced space heating.

#### Ventilation

The HVAC consultant was not participating during the whole project, since he changed his job halfway through. The change of consultant was an additional cost for the project.

The additional cost for the by-pass function in the ventilation unit was SEK 32 000 + VAT for all 40 units.

#### Measurements

The measurements of airtightness were made by the construction company Skanska and the additional cost for this was SEK 75 000 to 100 000 .

#### Household appliances

In the beginning of the planning, the client wanted very energy efficient white goods with the energy class A++. These turned out to be very expensive and in discussions between the client and the contractor, they were removed from the list of demands. Later on in the project, the client changed his mind and decided to buy the very energy efficient household appliances. Since this was not a part in the original offer from the contractor, it became an additional cost of SEK 162 000 + VAT for the client.

### 3.11.2 Rental costs

The companies in Sweden included in SABO; Swedish Public Housing Companies, have calculated the mean values of their rents (including heating). In Sweden this level in 2004 was SEK 754 /m<sup>2</sup>,a. The client Finnvedsbostäder has in 2004 a mean value of SEK 718 /m<sup>2</sup>,a. The mean value of the rent in these new passive house apartments is approximately SEK 888 /m<sup>2</sup>a, excluding heating. The rents for the apartments are:

- 2 rooms, 62 m<sup>2</sup>; SEK 5 100 (984 SEK/m<sup>2</sup>a)
- 3 rooms, 80 m<sup>2</sup>; SEK 5 700 (852 SEK/m<sup>2</sup>a)
- 4 rooms, 105 m<sup>2</sup>; SEK 7 600 (862 SEK/m<sup>2</sup>a)
- 5 rooms, 107 m<sup>2</sup>; SEK 7800 (876 SEK/m<sup>2</sup>a)

In this rental cost, heating, household electricity and domestic hot water are not included.

## 3.12 Additional Experiences

Everyone, from consultants to the plumber, working in the project was aware of the specification of requirements and was thinking about airtightness and quality issues at all times. To keep a good feeling of teamwork, every Friday a meeting was held on site. The work done during the week was discussed, also if new solutions had been found or if problems had

occurred. The contractors say that these meetings have given a great feeling that each carpenter's achievements really count; a feeling of importance. This also makes the people involved in the project proud of the result and they all delivered the project to the client with really straight backs.

When the contractors had questions or needed more detailed drawings or documents, they contacted the architect and the constructor and received the document needed. This collaboration has turned out to be very positive for the final result of the project, with solutions well thought through. The contractor says that it is important that the people working in these kinds of projects are experienced. You have to work confidently and methodically.

The time schedule has been very tight; everyone involved in the project knew that from the beginning. The contractor does not think that this has affected the final result and the project was finished on time. The high demands that were set up were achieved by having more staff on site. But even though the contractor thought about hiring more staff to this project than usual, they were undermanned and needed more carpenters. There were extra working hours in making the double frame and closely sealing the plastic foil. It was hard to find extra personnel when the project was running, which made the people on site work extra hours to be finished on time. Next time the planning of hiring extra personnel, if required, will start earlier.

The contractor thinks that it has been fun participating in the project, with many new solutions and ideas that can be brought forward to later projects.

The client has, after a close evaluation of the project, decided to continue with passive houses and is now planning for new multifamily houses with 50 apartments built to passive house standard.

## 4 The Frillesås project

Frillesås is a small village on the Swedish west coast, located between Varberg and Kungsbacka. The latitude is 57°19'0"N. The village has approximately 3000 inhabitants, more in the summer due to its lovely location close to the sea. The demand for apartments in the area is increasing and more apartments are needed to be built.

The passive house project in Frillesås consists of three houses in two storeys with a separate building for technical equipment and separate garage buildings. The three houses are part of the public housing sector and contain 12 rental apartments with two, three and four rooms.

### 4.1 Decision

Eksta Bostads AB is the community-owned housing company in Kungsbacka rural district, founded in 1965. Good solutions regarding environmental issues have always been a natural part for this company when planning new buildings. In the company's own district heating system, solar energy and biomass are used to produce heat for apartments and commercial buildings. The surplus of the district heating from this system not used in Eksta buildings is bought by other house owners that are connected to the district heating system. By now, the company owns 6500 m<sup>2</sup> of solar collectors. A future goal for the company is to reduce the use of electricity by 2% per year and owned square metre of living area.

Since 1982 solar collectors are always installed when Eksta is building new houses and the existing building stock has a very low energy demand due to carefully planned buildings. From this quality level, there was no big step from their normal building standard to start to build passive houses. The managing director of the company presented the passive house concept for the board of directors. They liked the idea of passive houses and also that this would be a project that would get attention in the media. A piece of land was already purchased in Frillesås and seemed suitable for the project. The project of building new passive house apartments in Frillesås started.

## 4.2 Basic requirements

The planning started with a working group of the client, the architect, the HVAC consultant and the structural engineer and resulted in a list of requirements for the project. In the application to become a demonstration project, which was sent to the Swedish Energy Agency, the following requirements regarding the buildings were specified.

U-values:	Windows: 0.85 W/m <sup>2</sup> K Exterior wall: 0.10 W/m <sup>2</sup> K Roof: 0.08 W/m <sup>2</sup> K Floor facing ground: 0.10 W/m <sup>2</sup> K (excluding foundation) Entry door: 0.6 W/m <sup>2</sup> K
Air tightness:	0.25 l/s, m <sup>2</sup> leaking area at 50 Pa. Both pressurisation tests and thermo graphic measurements should be used.
Acoustics:	Swedish Class B, including walls between apartments and floors. In living rooms and bedrooms this means that 26 dB(A) is the highest allowed sound level from interior installations and in kitchens 35 dB(A) is allowed. Noise from outside should not be higher than 26 dB(A) in rooms and 31 dB(A) in kitchens (SS 02 52 67 utgåva 3, 2004).
Household appliances:	Energy class A++
Air heat exchanger efficiency:	85%. The efficiency should be checked during the first year.
Solar collectors:	Yes, for domestic hot water
Drainage heat exchanger:	No

## 4.3 Planning

The planning process resulted in the three buildings with a total of 12 apartments in two storeys. The client wanted the new buildings to give a light exterior impression, not as dark as he thinks the Lindås project is. The architect wanted to use ferrous sulphate to give the facades a worn



impression. This caused long discussions together with the question whether ferrous sulphate will protect the wood over a long time. Finally, the client decided to use ordinary paint. He based his decision on the general opinion in the board of Eksta Bostads AB who think that with ferrous sulphate, which is not so commonly used, people might think that these are not ordinary apartments, but something special. The board wants the apartments to be just as their regular apartments.

It was hard to make up the time schedule since many of the working operations were new to everyone involved. For instance, the carpenters had to make a new roof construction, which would take some time to learn. The client together with the general contractor tried to make a time schedule well adjusted to the process. The client decided to have a flexible schedule, easy to change if necessary. To finish at a certain date was not as important as a good result. The sub-operations were therefore allowed to take as much time as they needed. The date to aim for, for the tenants to move in, was the first of September 2006.

## 4.4 Constructions

The apartments have two, three or four rooms with either a balcony on the upper storey or a patio on the ground floor (Figure 4.1). The ceiling height is 2.6 m.



Figure 4.1 Floor plans of the houses in Frillesås (efem arkitekter).

The bathroom floor cover is quarry tiles and the rest of the apartment floors have a wooden surface material. The indoor walls are wall-papered and the bathroom walls are tiled.

Table 4.1 U-values of the building envelope parts.

Building envelope	U-value [W/m <sup>2</sup> K]
Ground floor (excl. foundation)	0.11
Exterior walls	0.11
Roof	0.08
Windows, average	0.85
Entry door	1.00

#### 4.4.1 HVAC – system

The air is supplied by mechanical ventilation with an air to air heat exchanger, one in each apartment, placed in the kitchen (Figure 4.2).



Figure 4.2 Ventilation unit.

The heat exchanger has an efficiency of approximately 85% according to the producer. During cold periods space heating is supplied in the supply air duct by a water heating battery of 1.0 kW (10.3 – 14.7 W/m<sup>2</sup>).

To avoid internal noise from the air supply unit, adequate silencers are mounted in the ventilation system; two on the supply air system and one in the exhaust air system, mounted close to the ventilation unit, see Figure 4.3.



Figure 4.3 Silencers.

The ventilation air flow is somewhat higher than normal to avoid too high temperature levels of the supply air when maximum heating is needed. The supply air diffusers are placed in the ceiling in the bedroom and in the living room. The exhaust air devices are placed in the bathroom, kitchen and in the walk-in closet. The filters in the ventilation unit are changed twice a year by caretakers employed by the client. Then information about the status of the apartment is also updated to the company.

In line with the company's goal of decreasing electricity use, the battery in the heat exchanger is run by domestic hot water. The water used in the heating coil in the battery has passed the mixer valve. To avoid any freezing problems in the battery, the exhaust air is heated before it enters the heat exchanger (Figure 4.4). If the heating battery had been placed to heat the supply air directly and the fans in the heat exchanger by some reason stop, the outdoor air would go unheated through the heat exchanger and be cold when passing the heating battery. If the outdoor temperature is below

0°C there is a risk that the water in the battery freezes. With placing the heating battery in the exhaust air outlet, there is always heated air reaching the battery. This solution might cause a reduction in the efficiency of the heat exchanger, which will be further investigated in the final thesis. Also, only about 80% (efficiency of the heat exchanger) of the supplied heat in the exhaust air will be supplied to the rooms. The rest will be lost to the extract air going out.

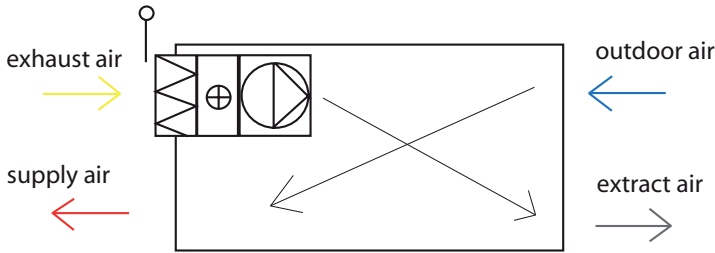
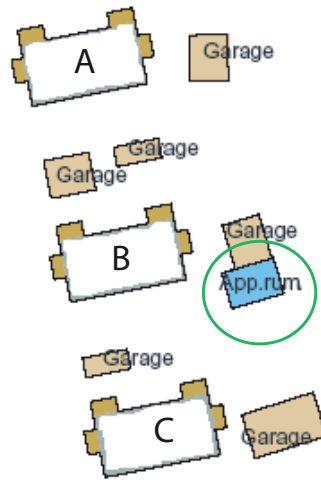

Figure 4.4 Heating battery placement in the heat exchanger.

There are two fans with five different settings in the ventilation unit, each using 58 W, both running 24 hours per day. Outdoor air is supplied from grilles mounted in the gable façade. Extract air is exhausted on the roof. A by-pass function is automatically regulated by sensors mounted in the exhaust air pipes. The by-pass function is blocked out at low outdoor temperatures by sensors placed in the outdoor air duct.

#### 4.4.2 Domestic hot water system

The domestic hot water is prepared by solar collectors and auxiliary heat is supplied by district heating. There are about 52 m<sup>2</sup> of solar collectors mounted on the roof of the apparatus building, see figure 4.6. Figure 4.5 shows the placement of the apparatus building.



*Fig 4.5 Apparatus building.*



*Fig 4.6 Solar collectors on the roof of the apparatus building.*

In this building all pumps and water heaters are placed and also the electricity distribution board for all buildings. The domestic hot water is heated to 60°C. Circulating hot water is used for the heating battery in the ventilation units and it also runs through a small heating coil in the bathroom floors. These heating coils have a temperature of approximately 35°C and are cast in the bathroom floors to give additional comfort. The water runs in the coil all year round and can not be turned off by the tenants because of the risk of legionella disease bacteria.

When the temperature sensor in the solar collector system exceeds 30°C the solar system starts to heat domestic hot water to the system. The liquid in the solar collectors goes in to a heat exchanger, heating water for the domestic system. The pump for this water starts when the temperature difference between the liquid at the top of the water tank and on the solar side of the heat exchanger is at least 5°C. Additional cold water is mixed with the solar heated water to reach the temperature level of 60°C. If the temperature of the solar heated water is not high enough, the water is heated further by district heating.

The mixer taps used are made to give a maximum water flow only when the tap is pressed further upwards. This prevents the tenants using more water than necessary. To decrease the use of energy the tap needs to be pressed all the way out to the left before it supplies only hot water.

#### 4.4.3 Household appliances

The combined refrigerator/freezer in the two room apartment uses 376 kWh/a according to the producer. The washing machine uses 1.02 kWh of electricity for each wash. The condensation dryer is equipped with a heat pump and uses only 2.1 kWh per program. The household appliances used are listed in Table 4.2.

Table 4.2 Components used.

Product:	Producer:	Name of product:
Windows	NorDan A/S	ND Sikkerhetsvindu ND Fagvindu ND Fast karm ND Sikkerhetsdør
Entry door	Dooria	YD 1217 Varberg
Washing machine	Miele	W1713
Tumble-drier	Husqvarna	QW490A
Mixer tap	Gustavsberg	Nordic TT
Freezer/Fridge	Miele	KFN 8462 SD
Stove	Electrolux	Insight
Kitchen fan	FRANKE	

## 4.5 Simulations

One of the three buildings in the Frillesås project was simulated in DEROB- LTH (Figure 4.7). This is of the building type A or C, with two and four room apartments.

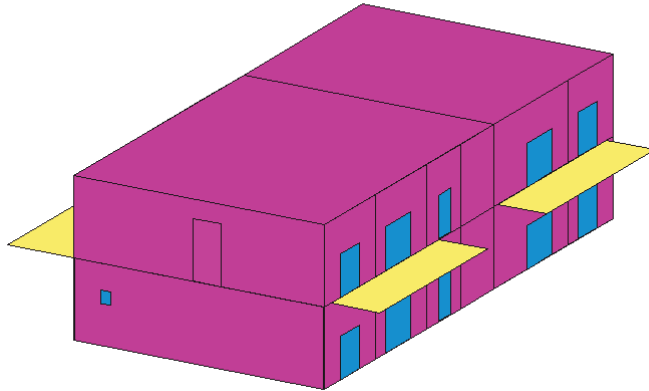

Figure 4.7 Building at Frillesås simulated in DEROB – LTH.

Input data in DEROB-LTH:

Space area: 330 m<sup>2</sup>

U-values: Floor facing ground: 0.11 W/m<sup>2</sup>K  
Outer wall: 0.11 W/m<sup>2</sup>K  
Apt separating wall: 0.08 and 0.18 W/m<sup>2</sup>K  
Inner wall: 0.2 W/m<sup>2</sup>K  
System of beams: 2.89 W/m<sup>2</sup>K  
Roof: 0.08 W/m<sup>2</sup>K  
Outer door: 1.0 W/m<sup>2</sup>K  
Windows: 0.7 W/m<sup>2</sup>K

Ventilation: Air leakage: 0.05 arch  
Mechanical ventilation: 0.5 arch  
Efficiency of heat exchanger: 80%  
Ventilated volume: 85%

Orientation: The building is rotated 11 degrees anti-clockwise from south

Soil resistance: 2.37 m<sup>2</sup>K/W

Ground reflection: 20%

Internal gain: 4 W/m<sup>2</sup>

Indoor temperatures: The indoor temperature was set to 20°C and 22°C respectively  
For the studies of energy demand and peak load the maximum allowed indoor temperature was set to 25°C. Above this temperature, the occupants are assumed to reduce the temperature by using shading devices and/or opening windows.

Climate data: The simulation was made with climate data for Göteborg

#### 4.5.1 Calculated results

With an indoor temperature of 20°C the peak load for space heating was calculated to 8.5 W/m<sup>2</sup> and the energy needed for space heating was calculated to 9.6 kWh/m<sup>2</sup>a. When simulating the building with an indoor temperature of 22°C, the peak load for space heating was calculated to 9.4 W/m<sup>2</sup> and the energy needed for space heating was calculated to 12.6 kWh/m<sup>2</sup>a. Additional energy demand caused by thermal bridges must be added to the calculated result. The simulations were based on placing the heating battery after the heat exchanger. Since the battery in reality was placed before the heat exchanger, the space heating demand and the



peak load will be higher than the simulated values. The influence on the energy demand due to the placement of the heating battery will be further investigated in the doctoral thesis.

## 4.6 Tendering

The client wanted to work with a contractor they have good relations with, had worked with before and had great confidence in. They engaged a local firm that fulfilled all these three wishes as a general contractor. This was not unique because it was a passive house project; they normally purchase their projects this way. The general contractor used competitive tendering to have tenders from 2 – 3 subcontractors for each trade. The subcontractors that received the invitation to tender had earlier worked with the general contractor with good results; only subcontractors that the general contractor wanted to work with got the chance to give a bid. The subcontractor with the lowest price got the contract. Since it was the first time the general contractor built a passive house; external help from Lund University/LTH was needed to find suitable components for the buildings.

## 4.7 Planning deviations

### 4.7.1 Entry doors

The contractor had trouble finding a door with the required U-value of  $0.6 \text{ W/m}^2\text{K}$ . The producer of the door used in the project at Oxtorget, Värnamo, wants to evaluate that door before using it in more projects. German doors with a low U-value are available but fabricated going inward and have to be changed to suit the Swedish market. A regular door costs between SEK 4000 – 5000 and the only offer received for a passive house door was on SEK 10 000 /door. Finally, a normal type of door was used and a glazed vestibule was built outside the entrance, to ensure a low thermal loss. It is designed as a buffer zone and for wind protection, see figure 4.8. The vestibule is not heated and it is ventilated by two vents.



Figure 4.8      *Glazed vestibule.*

## 4.8 Training

In December 2005 architect Hans Eek gave a training lecture for all carpenters participating in the project, which also included an educational visit to the terrace houses in Lindås. Not only the carpenters who would be on site, but also the carpenters making the prefabricated constructions, the foundation contractor and the electrician participated. The general contractor decided that if more training was needed regarding specific detailed solutions, instructions would be given on site right before the work should be performed.

The airtightness and the careful construction work were the two main impressions from the visit in Lindås. The carpenters learned that the maximum size of the total holes that is allowed in the walls is the same size as an “O” shaped with both their hands. They all think that the training visit was very positive, that it was good to look at a real construction. The general contractor observed that no new materials were used; it was all traditional materials but built with a high accuracy and more insulation and plastic foil than usual. The contractor said that using traditional

materials makes it easier to implement passive houses on the conservative building market.

Since the buildings in Lindås were finished a long time ago (in 2001), it was impossible to see how the constructions were made. Models of the constructions like the one used in the Värnamo project would have been a good idea to use to illustrate the construction.

## 4.9 The construction stage

### 4.9.1 Foundation construction

The work on the foundation started in November 2005. The foundation construction was founded on a layer of macadam. On top of the macadam-layer there is 200 mm of EPS covered with plastic foil and then another layer of 100 mm of EPS. 100 mm of concrete cast on site covers the two layers of EPS (Figure 4.9).

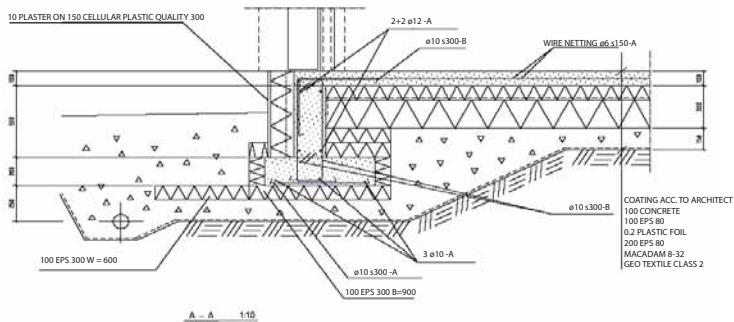

Figure 4.9 Foundation construction (WSP konstruktion).

There is no electrical coil heating the concrete to speed up the drying process. The requirement for moisture content in the concrete before floor covering was a RH of 85% or lower.

The work with the slab on the ground started in February 2006. At that time it was unusually cold for the season and there was still frost in the ground. To be able to start with the casting of the slab, the ground was heated by heating fans. There was a lot of snow, and the concrete slab was covered up with a tarpaulin at every coffee or lunch break and at night.

Since it was so cold, there had to be many breaks so the workers would have a decent working environment.

In the concrete slab the drying process worked as normal and measurements before the surface material was applied showed a moisture content of 85% at a depth of 4 – 5 cm.

Casting the slab on the ground took much extra time, but this had nothing to do with the fact that it is a passive house. Starting the work with the slab in February was not a good choice. It was difficult for the carpenters to work when it was so cold with the covering and the uncovering on the concrete slab and the electrical wire cast in the slab. The local manager thinks that the efficiency of the foundation work was approximately 50 percent.

The electrician said that the main electrical wire should have been placed in the slab, to increase the airtightness and reduce the extra sealing work. Now the wires are placed in the outer wall.

#### 4.9.2 Loadbearing structure

The loadbearing structure in the internal walls is prefabricated and made of an insulated steel beam construction, covered on both sides with gypsum board. On the walls around the bedrooms an additional gypsum board was mounted as a noise barrier. On the internal walls between the apartments, three gypsum boards were mounted according to fire regulations. Every apartment is a separate fire compartment. In buildings A and C, the wall that separates the apartments goes all the way up to the roof. This makes the borders of fire easy to make. In building B, the wall that separates the apartments cannot go up to the roof; it would need to pass a roof truss, which is impossible. The attic therefore needed to be a separate fire compartment.

Separating the two storeys is a 300 mm prefabricated filigree system of beams. The filigree system consists of 45 mm prefabricated reinforced concrete. After this has been mounted, additional reinforcement between the tiles is placed and the rest of the concrete is cast on site. The prefabricated part of the beams has a w/c ratio of 0.35. The added concrete has a w/c ratio of 0.5. When the system of beams was cast the construction was covered up with tarpaulins, almost like a tent, and heated; to be able to cast the concrete it was necessary to keep the concrete warm underneath.

The system of beams used here; pre-stressed and 300 mm, is extra thick compared with a normal thickness of 230 mm. The extra thickness is due to the loadbearing construction and also to ensure that no sound will pass between the floors. To speed up the drying process of the concrete an electrical coil is cast in the upper part of the system of beams.

In May 2006, 6 month after the casting, the moisture content in the system of beams is still very high. The contractor made some approximate measurements that show that the RH in the concrete is 95% at a depth of 20 cm. At a depth of 10 cm, the RH is 85%. Normally the moisture in a concrete beam will dry two ways. The combination of the filigree construction and the extra thickness of the concrete make this a slow one-way drying process. The estimation made in the planning process regarding time needed for the drying process did not correspond with reality. Additional measurements were made to monitor the drying process. The client was very definite that no moisture problems should occur and that the drying process should take the time that was necessary.

The producer of the wooden based flooring material claims that it is acceptable with a relative humidity of 90% in the concrete. Measurements of the moisture content in the system of beams were made before the concrete was covered with the flooring material. The measurements showed that the concrete still had a moisture content of about 90% RH. The client then gave instructions to the carpenters to clean the concrete really carefully. The authorised inspector said that it is hard to clean all the organic material away, some of it might have penetrated into the pores in the concrete. The floor covering was then put on.

The electrical heating coil in the system of beams was placed on top of the reinforcing mesh, in the top part of the concrete cast on site. If the coils had been placed closer to the part of filigree-work, maybe the drying process would have been quicker. The best solution of the drying would have been to use concrete of higher quality, thus a lower w/c ratio.

#### 4.9.3 Exterior walls and windows

The exterior walls were prefabricated and completed on site. These walls are 6 metres high and 2.5 metres wide, high enough to cover two storeys and avoid joining two parts together in the middle. This secured the airtightness and quality of the project. The prefabricated walls were mounted in three days. After the prefabricated part of the walls was mounted, they were covered on both the inside and outside by polystyrene (Figure 4.10). The polystyrene on the inside of the walls was cut on site, making the window-bay bevelled. The carpenters found that if they used brick wedges when cutting the polystyrene, the bevelled construction was easy to make. The risk of moisture content in the construction was minimized when the walls and roof were mounted fast.



*Figure 4.10* Walls covered by polystyrene.

On the inside, plastic foil sealed the construction and was covered with wooden frames together with insulation. On the outside, the wooden facade material was mounted on wooden frames attached to the polystyrene. The wooden panels were primed at the factory before erection.

It is important to measure the moisture content in the sills before the polystyrene is mounted. After the polystyrene is mounted, almost no moisture will be able to dry out. The general contractor usually measures the moisture content in the wood sills in all their projects, so this is nothing special for a passive house construction. But in an ordinary construction, a heating coil in the slab often gives additional heat to the construction and dries out the moisture. Here, to protect the wooden sill from moisture in the concrete slab, a sheet of soft plastic is put between the sill and the concrete on both sides of the wall, see Figure 4.11.



*Figure 4.11* Moisture protection in the wooden sill construction.

The gypsum boards in the walls are protected from moisture in the construction by ending the boards a bit above the concrete. In future projects, instead of using a wooden construction, a metal sill can be used to decrease the risk of moisture problems. The structural engineer said that this will not cause any extra thermal bridge but the joists of steel can be unstable when not loadbearing.

The plastic foil mounted on the inside of the polystyrene on the wall was large enough to reach from floor to ceiling. Since the plastic could be mounted without cutting, the sealing work runs very smoothly. Both the carpenters and the local manager had opinions on the way the airtightness process was carried out. They all think that a work checklist would have been nice to use where all working operations are written down to make sure in future projects that no working operations are neglected and that the process is carried out the right way.

The carpenters said that it was difficult to know how to reach the goal set up for the airtightness. How much work is enough to make sure that not too much or too little time is used? An effective production does not allow making a trial test for airtightness in one apartment. The contractors want to do the same sub-operations in all the apartments to make the production effective. To almost finish one apartment will cause an interruption in the production. The hardest part has been to make the buildings airtight around doors and windows.



The window type had earlier been used in two pilot projects in Norway. It is a window construction that has been used for a long time with a higher U-value, which has now been improved. It is Drehkipp windows, operable so the tenants can use window ventilation without moving their flower plants.

The bathroom windows have a sandblasted middle pane, so-called Matelux. It allows low emissivity coatings on the outer and inner pane but can not be seen through. Normally, textured glass panes are used to prevent a view into the bathroom, but textured glass can not have low emissivity coatings. Using the sand blasted pane keeps the low U-value on the bathroom windows.

Both the regular windows and the bathroom windows have a total U-value of  $0.7 \text{ W/m}^2\text{K}$  according to the producer. The window consists of three panes; two with low emissivity coatings and with 16 mm gaps filled with argon gas between the panes; 4ES + 16G + 4 + 16G + ES4.

The balcony door also has three panes; two with low emissivity coatings and argon in the gaps between the panes. Here the gaps between the panes are 12 mm; 4ES + 12G + 4 + 12G + ES4. This gives a total U-value of  $1.1 \text{ W/m}^2\text{K}$  for the door according to the producer.

The entry door has a round window, 35 cm in diameter. The total U-value of the door, according to the producer, is  $1.0 \text{ W/m}^2\text{K}$ .

To mount the windows, first the glazing unit had to be taken out of the frame and then the frame was mounted in the wall. Then the glazing unit was placed into the frame again to make sure the window was horizontal. To be able to adjust the window, the glazing unit had to be taken out of the frame again. It turned out to be impossible to adjust the window when the glazing was still in the frame. A handle on the side of the pane stops the window from opening 90 degrees, necessary for adjusting. The carpenters suggested that the handle should be detachable from the frame when adjusting the window. It was the first time the carpenters worked with windows like these that came assembled, not in separate parts.

Experiences from other apartment buildings built by the client show that tenants do not like windows that open inwards. The contractor therefore needed to find windows with both a low U-value and a Drehkipp construction, not an easy task to do on the Swedish market at this time. Many manufacturers were contacted to give an offer. The windows offered mostly had a higher U-value than required, were really expensive or not operable as desired. The Norwegian company NorDan Windows has windows that fulfil all demands regarding U-values and operability, but the first bid was too expensive. However, NorDan AS was really interested in introducing these windows on the Swedish market and the market of energy-efficient buildings and was therefore willing to give a better price. The final price was approximately 10% higher than the contractor had



counted on. The total window area is 56 m<sup>2</sup>, which gives the price SEK 2195 /m<sup>2</sup> (window area). When the windows were purchased, NOK 100 were SEK 82.78. This currency difference also affected the price.

#### 4.9.4 Roof construction

After finishing the walls, the roof was mounted and covered with roofing felt. It is a wooden construction, sealed with plastic foil between the apartments and the attic, see Figure 4.12.



*Figure 4.12 The attic, before the insulation was put in place.*

When the roof had just been covered with roofing felt, lots of snow came so the roofing tiles were not put up until later. This delayed the mounting of insulation. Loose wool insulation was put on the plastic foil after the airtightness measurements.

During the pressurisation tests of building B it was discovered that when overpressure was applied, the plastic foil on the attic rose like a big balloon. Air went from one apartment to another without any obstruction. The plastic foil in the internal wall in the connection between the walls and the height of the attic floor was not sealed with the reinforced plastic foil in the attic (Figure 4.13).

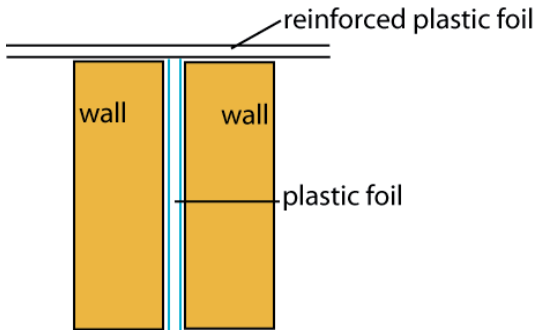

Figure 4.13 Plastic foil in internal walls meeting plastic foil in the attic.

The construction of building B did not allow the wall between the apartments to go through the attic up to the roof, see Figure 4.14. Then it would have needed to pass a roof truss, which was impossible. The plastic foil was later sealed by the carpenters.

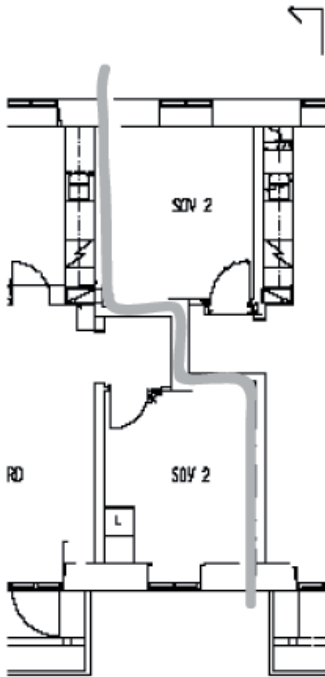

Fig 4.14 Construction of the wall separating apartments, building B.

The attic is not mechanically ventilated, but ventilated by two air vents. The roof has a micro porous membrane attached to the tongue where moisture easily gets through but water molecules are too large.

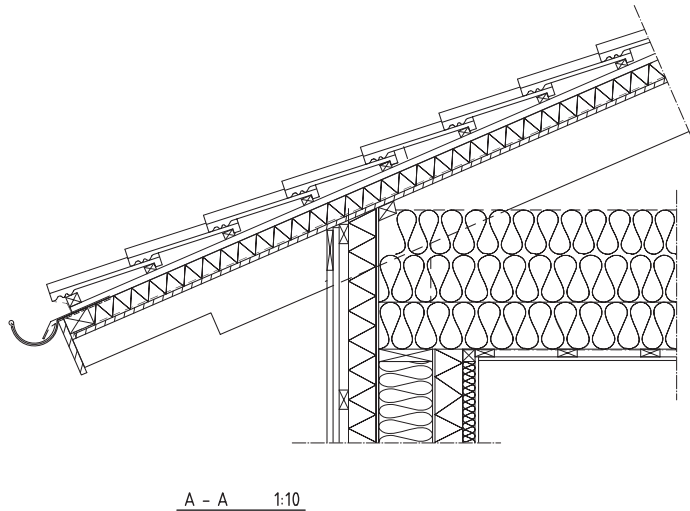

Figure 4.15 Design of roof construction (WSP konstruktion).

#### 4.9.5 Ventilation

The ventilation units are placed in the kitchens as in the Lindås project. A gully is put under the washing machine, where the foul water from the unit is let out. In this project, it seems that a better placement for the units would have been in the bathrooms. Since the ventilation unit in the kitchen is not built-in, the noise from the fans is easily spread in the open planning of the apartments. The ventilation flow at its highest settings is 50 l/s per apartment.

In the planning process a framework document was made for the ventilation system. When the project started, the subcontractor for the HVAC system had not yet been engaged, which made it impossible to include them in the initial training about the principles of building a passive house.

The information that the houses were planned to be heated by the ventilation air was not grasped by the subcontractor. The detailed drawings of the ventilation system were therefore based on airflow rates needed for normal ventilation in apartments, with no possibilities for a higher air flow if needed to cover a high energy demand. No insulation was planned for around the pipes.

The subcontractor thought the project meetings took too much time and that he did not get paid for participating in meetings in this project. Since the subcontractor did not participate in the meetings, it took a long time before it was discovered that the drawings made by the subcontractor were not suitable for the project. The drawings were given to me for evaluation and I found that we needed to improve the ventilation solutions to make these houses work like a passive house.

To ensure that the ventilation in the apartments will work as planned, the HVAC consultant made complete documents for the ventilation system. The pipes were now larger and insulation was added around the pipes. This late in the project, there was no extra space in the suspended ceiling for this larger construction. The subcontractor together with the HVAC consultant then decided to put the pipes in the attic. The perforated plastic foil was closely sealed on all places where the pipes go up on the attic. Additional silencers were added to make sure no internal noise is generated from the fans in the heat exchanger.

#### 4.9.6 Domestic hot water

The company that normally produces the solar collectors used by the client, now only sells the parts for the units. Therefore, the carpenters mounted the units together on the roof, using drawings to make the solar panels working as approved by SP Technical Research Institute of Sweden.

The placement of water pipes in the rooms coming up from the slab on the ground was not good. The pipes were not easy to separate in the mounting process and were not insulated. The hot water flowing through the uninsulated pipes might give additional heat to the bathrooms.

## 4.10 Measurements

### 4.10.1 Airtightness

The client decided that all apartments should be measured for airtightness and two apartments should be measured also with differential pressure across the apartments, and not only for the building envelope. These measurements should be performed when all holes had been made for building installations. The measurements were performed by SP Technical Research Institute of Sweden.

The first measurements were performed the last day of May, 2006. The studied apartments are put under the pressure of +/- 50 Pa. The walls towards other apartments are not put under pressure. The surfaces used for air leakage were all the wall areas including the walls between the apartments.

The required airtightness of  $0.25 \text{ l/s, m}^2$  would be equal to a leakage flow of 77.8 l/s in buildings A and C ( $311 \text{ m}^2$ ) and 68.8 l/s in building B ( $275 \text{ m}^2$ ). According to a required airtightness of maximum  $0.8 \text{ l/s, m}^2$ , in the old regulations in BBR, these flows should be 248.8 l/s in buildings A and C and 220 l/s in building B.

When the apartment was prepared for the measurement, the door to the balcony was replaced by a wooden board, see Figure 4.16. In the wooden board a fan with a variable number of revolutions was mounted in the centre. To measure the differences in air pressure, a tube is drawn from outside, through a hole in the board, and attached to the fan (Figure 4.17).



Figure 4.16 Wooden board mounted for airtightness measurement.



Figure 4.17 Fan and tube mounted in the wooden board.

To make sure that only the building envelope of the apartment is measured, water is poured in the gully and all unattached pipes are taped. First the air leakage was measured when the apartment was under vacuum, then it was measured with overpressure. The mean value of air leakage measured should be below the project requirements ( $0.25 \text{ l/s, m}^2$ ).

First, building A was measured. This building was very airtight, both with overpressure and vacuum. The mean value of the measurements showed an air leakage of  $0.18 \text{ l/s, m}^2$ . Building B was not that airtight. The mean value was  $0.33 \text{ l/s, m}^2$ . Thus, it was not below the air leakage wanted in this project but still much below the Swedish regulations in BBR ( $0.8 \text{ l/s, m}^2$ ). When the joints between the different concrete beams were looked at, air was coming up from the apartment below. Also around the windows, air was leaking. The carpenters got this information and started right away to improve the airtightness. Building C was not measured at this time.

Fifteen days later, building B was measured again. All the joints connecting the concrete beams had been sealed with silicone. The carpenters said that the process of making the building more airtight had taken approximately three days. Despite this, the air leakage continued in this second measurement, probably due to air leakage in the attic. The electrical sockets that were mounted in the wall between the apartments caused a

considerable air leakage. Airtight electrical sockets should have been used in the walls between the apartments.

Building C was sealed in the joints just like building B, after the first measurement of airtightness. When the airtightness was measured in building C, it showed that the carpenters had done a very good job. The air leakage through the shell in building C was very low, see Table 4.3. This confirms that the problem with the airtightness in building B is the plastic around the wall between the two apartments in the top floor, see Section 4.9.4.

The plastic in building B was closely sealed and new measurements were made. The total average air leakage in the three buildings was 0.19 l/s,m<sup>2</sup>.

Table 4.3 Airtightness at 50 Pa for the building envelope for all 12 apartments including surfaces to adjacent apartments.

Building	Apartment number	Air leakage (l/s,m <sup>2</sup> )	Average air leakage (l/s,m <sup>2</sup> )
A	1	0.11	
A	2	0.15	
A	3	0.16	
A	4	0.24	
A			0.17
B	1	0.11	
B	2	0.15	
B	3	0.21	
B	4	0.29	
B			0.19
C	1	0.14	
C	2	0.21	
C	3	0.21	
C	4	0.33	
C			0.22

#### 4.10.2 Airtightness measured for the building envelope alone

Two apartments in building B are measured with backpressure. To measure with no differential pressure across the walls separating the apartments shows how much air is leaking through the climate shell from the studied apartment to outdoors. This is done by creating the same pressure in adjacent apartments as in the studied apartment (Figure 4.18).

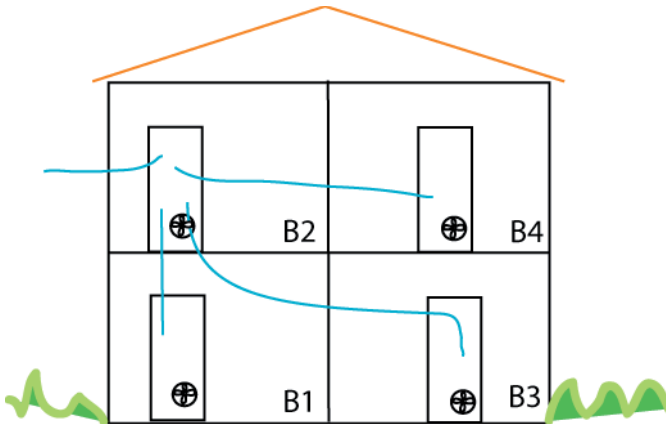

Figure 4.18 Apartments measured with backpressure showing fans and tubes.

First, apartment B1 was measured, and then apartment B2 was measured in the same way. In all the apartments in building B a wooden board was placed in the opening of the door to the balcony. A fan was placed in each of these wooden boards. All fans in the different apartments could be controlled from the measured apartment. They were controlled with an adjustable transformer, so the pressure in the apartments could vary separately (Figure 4.19).



Figure 4.19 Ingmar Nilsson of SP measuring the air leakage.



A tube was drawn from inside all four apartments in building B, into the apartment where the airtightness was measured. The ends of these four tubes were attached to a pressure gauge, one gauge for each tube. Then the air leakage was measured. Inside and outside temperatures, atmospheric pressure and wind velocity are measured and also taken into consideration.

The measurements showed that the electrical sockets in the wall between the apartments were leaking air, like in earlier measurements (Figure 4.20).



*Figure 4.20 Measurement of air leakage through electrical sockets.*

It showed that some sockets were leaking more air than others. There was also air leakage in the conduits for electrical wires. This air leakage between the apartments could cause problems later on due to the diffusion of cigarette smoke, cooking smells and other odours between the apartments. The results are presented in table 4.4.

Table 4.4 Airtightness at 50 Pa for the building envelope alone, measured with no differential pressure across the inner surfaces of the two apartments in building B.

Building	Apartment number	Air leakage (l/s,m <sup>2</sup> )
B	1	0.08
B	2	0.11

## 4.11 Moisture

The measurement of relative humidity in the filigree system of beams started in May 2006. They were performed by SP Technical Research Institute of Sweden. Early measurements showed high moisture content in the concrete. To avoid building in too much moisture, it was important that the drying process was closely followed.

### 4.11.1 Method of measurements

Twelve holes for measurements were drilled in the concrete to three different depths; 92 mm, 106 mm and 120 mm. 92 mm is 40% of the depth of the concrete cast on site (230 mm). 120 mm is 40% of the total depth of the beams (300 mm). 106 mm is between these two depths. The gauges were placed at two places on every depth; one in the middle of the beams(longest time for dry-out) and one in the end of the beams . The local manager checked the gauges once a week.

The electrical coil in the concrete was supposed to speed up the drying process. But it also made the indoor climate too hot to work in. To keep a good working environment, the coils needed to be turned off.

In august 2006, the relative humidity in the concrete was still very high. The measurements showed the temperature in the hole and the relative humidity at that temperature point. Since the temperature varied significantly it was impossible to compare the results and to see a trend in the humidity change. The electric coil in the concrete also made the temperature in the concrete really high at some measurements. This method of measuring the relative humidity was not suitable for this project. New measurements were performed, this time according to the Swedish “RBK-method” ([www.rbk.nu](http://www.rbk.nu)). In October 2006 SP Technical Research Institute of Sweden measured the relative humidity by this method in the three buildings.

There were five points of measurement, two on the ground floor of buildings B and C, and three on the system of beams, one in each build-

ing. In building A, the flooring material on the ground floor was already laid on at this time, so no measurements were made there. The measurements in the system of beams were made in between the heating coils in the concrete. The three depths for measurements were 75 mm, 150 mm and 225 mm. The results are shown in Table 4.5. The relative humidity in Table 4.5 refers to corrected RH at 20°C including uncertainties in measurements. To be able to put on the flooring material, the relative humidity in the concrete needed to be below 90%.

The results show that in the concrete slab in both buildings B and C, the relative humidity is low (Table 4.5). The measurement of the system of beams shows a higher level of relative humidity.

Table 4.5 Measurement of moisture content in the concrete.

<b>Building A:</b>			
Measurement point:	A2 (75 mm)	A2 (150 mm)	A2 (225 mm)
Date:	2006-10-23	2006-10-23	2006-10-23
Temperature, concrete: (°C)	25.4	25.4	25.4
RH concrete: (%)	85.8	89.8	90.3
<b>Lower floor buildings B and C:</b>			
Measurement point:	B1	C1	
Date:	2006-10-23	2006-10-23	
Temperature, concrete: (°C)	24.5	27.0	
RH concrete: (%)	81.3	76.2	
<b>Upper floor, Building B:</b>			
Measurement point:	B2 (75 mm)	B2 (150 mm)	B2 (225 mm)
Date:	2006-10-23	2006-10-23	2006-10-23
Temperature, concrete: (°C)	25.9	25.9	25.9
RH concrete: (%)	90.0	92.5	91.9
<b>Upper floor, Building C:</b>			
Measurement point:	C2 (75 mm)	C2 (150 mm)	C2 (225 mm)
Date:	2006-10-23	2006-10-23	2006-10-23
Temperature, concrete: (°C)	26.2	26.2	26.2
RH concrete: (%)	85	90.2	88.4

The evaluation of the relative humidity in the system of beams was based on measurements at three different depths (moisture profile) by using the mean value of the highest and the lowest measured value in the meas-

ured points (Olsson, 2006). This gives the results of 88.1% RH in A2, 91.3%RH in B2 and 87.6% RH in C2.

## 4.12 Further measurements

In one apartment SP Technical Research Institute of Sweden is making detailed hourly measurements of the indoor climate, starting on the first of February, 2007. Also outdoors, measurements of diffuse and direct solar radiation, outdoor temperature and wind velocity are made. The measurements will be in progress for 6 months. My future research work at Energy and Building Design includes the evaluation of these measurements.

### 4.12.1 Measuring methods

The supply air temperature is measured by sensors mounted inside the supply air devices and the temperature of the exhaust air is measured by sensors hanging outside the exhaust air devices. In front of the windows, 1.0 metre into the room and 1.1 metre above the floor, a sensor is mounted measuring the operative temperature, one in each room. A cylinder with a hole is placed in every room with a bulb mounted in each cylinder, giving off 75 W in the living room and 60 W in the other rooms. In all apartments, a sensor measuring the indoor temperature is mounted. It is placed 1.1 m above the floor, protected from direct sunlight and from radiation from lamps.

## 4.13 Economy

In the first interview the client said that when the company builds ordinary apartments, the price is about SEK 10 400 /m<sup>2</sup> including the cost for the foundations. For these passive houses, the client calculated with SEK 12 000 /m<sup>2</sup>. The piece of land cost MSEK 1.3. This is approximately SEK 110 000 per apartment.

After the finalization of the project it turned out that the total production cost of the apartments and the garages was approximately SEK 14,500 /m<sup>2</sup>. This includes the piece of land, connections for water and sewerage system, connection to district heating and VAT. This is a more exclusive project than regular apartments built by Eksta, regarding surface materials.

The client thinks that in a regular building project of about 50 ordinary apartments, the production cost would now be about SEK 13 000 – 14 500 /m<sup>2</sup>.

Additional costs for building a passive house are estimated by the client to total SEK 150 000 – 200 000 for the project, or SEK 200 /m<sup>2</sup>. The additional cost is mostly for using more hours in the construction work. The general contractor said that an ordinary apartment takes approximately 800 h to finish. In this project each apartment took 1000 h. The additional time needed was mostly for making the project as airtight as required. The general contractor had estimated an additional cost of 15 – 20% since this was something they had never built before. Thanks to this, the general contractor kept his budget.

The costs for consultants were 8.5% of the total cost, and the contractor 86% of the total cost. The consultant costs are high in relation to other projects. The client think this cost could be cut by half in the next passive house project.

To build four-room apartments is not the ideal if you want Swedish investment grants. The client estimated that they lost some hundred thousand SEK because of building four room apartments, but also said that it is more important to have an apartment with a good function than to get the maximum grant.

The monthly rent for these passive house apartments varies between SEK 5500 and SEK 7900(SEK 960 /m<sup>2</sup>a – SEK 977 /m<sup>2</sup>a). Every apartment will pay for its own use of electricity and domestic hot and cold water. Space heating “according to passive house standard” is included in the rental cost. The meters will be placed in the bathrooms.

#### 4.14 Additional experiences

The basic attitude in this project was that this is not a special project. When you are building passive houses you just do as usual – but a little bit better. Because of this attitude, a close discussion of the project might have been forgotten in the beginning of the planning process, with the basic knowledge and building techniques for passive houses. At the final meeting, everyone involved in the project agreed that such an informational starting meeting would really have been appreciated and made the project easier. The contractors who did not have the opportunity to participate in the visit to Lindås felt that they were not fully aware of the passive house concept.

The subcontractors said that a short informational text about passive houses should be an introduction in the document when tenders are in-

vited. This is important not only for the information but also because it affects the price. The time for making the buildings airtight needs to be considered in the bid. The client thinks that it is important not only to focus on the lowest price but also to aim for a well performed work with a long-term perspective.

To accomplish the project as a general contract, the general contractor needed to carry out the project after his level of attainment. The client thinks that this has worked very well in this project, both in the work with the construction and financially, and that the general contractor has achieved the knowledge necessary to build passive houses.

The drawings regarding construction were very general; no detailed drawings were made. The general contractor encouraged the consultants to make as few drawings as possible, if there had been a need for more drawings he would have ordered them during the working process. No construction details are said to be needed when you have good communication at the working site. The consultants were uncertain about how much detail the drawings should have. The architects felt that this overall planning made them less involved in the project. No discussion about e.g. the placement of the air supply unit was held. This might also have resulted in lack of commitment. The HVAC consultant thought it might have been better if they had made a complete set of drawings instead of just a framework document. In this project that used a new way of construction for apartments, the ventilation system needed to be closely specified, instead of solving the details on site. One of the carpenters said that a detailed drawing might have been used for the first construction, then it would have been ignored and a more suitable way of construction devised by the carpenters would have been used. Now, he says, the more suitable way of construction was chosen directly.

There is a risk that when the carpenters make their own solutions, these might not be the best solution for the project in total and for the passive house concept. To have control over the solution used, a good idea would be to have the solutions approved by a person in the project, who is responsible for energy and concept issues with an overall view of the project.

The co-ordination of the project worked rather well. Everyone who has been working on site agreed that there has been good communication between the different subcontractors and that all subcontractors showed respect for the work of others. All subcontractors involved in the project needed to take the importance of air tightness seriously. Holes made in the climate shell by another contractor should not need to be fixed by the carpenters. Everyone needs to take their responsibility.

There was no co-ordinated review of the drawings. If this had been held during the time for framework documents, mistakes now made on site

might have been discovered and would have been cheap and easy to put right . Problems that occurred were instead solved by the subcontractors during the progress of the project together with the general contractor. The general contractor said that it is necessary to have an expert who checks the drawings and the documents early in the project, to make sure it will work as a passive house.

The carpenters said that the building process has been longer than usual, but it has been fun to be a part of the project. There has been no rushing and tearing about and if you had questions you could always ask the local manager, if he was present.

The working team had no meetings on site; at coffee breaks no job is discussed. There seemed to be no natural meeting point for the carpenters briefing new ideas or trying to solve problems that occurred. A monthly meeting was suggested for following projects by the carpenters, to catch up about the conditions on the project. The general contractor said that there have been eight carpenters at the most at the construction site and they communicated well with each other. They did not need weekly instructions to know how to work, they knew it anyway and the general contractor knew that they did a good job, they trusted their carpenters. The client said that this culture results in higher quality at a lower price. The general contractor claimed that the communication between the carpenters and the local manager has been good as well. The communication was very informal and all subcontractors said that it was easy to work with the general contractor.

The time to finish this project at the building site was 10 – 11 months. It is important to think of the completion date for the project. Generally, there is a short time between the planning and the work on site in the building industry today. Because of appeals against building projects, projects have to start at a time that is not suitable . For instance it is not suitable to plaster or paint a façade in February. It is also important that there is time to prepare the exterior environment; the tenant should not move in to a working site.

The responsibility for the project fell somewhere between the planning documents made by the consultants and the performance of the contractors on site. The general contractor had the major responsibility for the quality of the project and to fulfil the demands set up by the client. It is important that there is a good relationship between the persons who make the design and the persons who realize the project and that they share the responsibility for making their best final result. The fewer detailed drawings that are made, the more responsibility passes from the consultant to the general contractor. This causes a gap between the consultant and the contractor and gives the contractor the major part of the experiences in the project. When only a small number of drawings are produced it will

be hard for the client to reproduce the project. The knowledge now stays at the general contractor.

A network for passive house builders might make the planning and tendering process easier; not only to find components but also to get examples of building constructions and experiences from other projects. However, here it is important not to copy solutions since this could result in bad solutions being reproduced just because it is safe to use something already tried. Furthermore, solutions used in one project might not work in another project.

When you rent an apartment from Eksta Bostads AB, you always have a personal meeting with a representative from the client. That makes it easier to transfer information about living in a passive house. During the first week after the tenants moved in, the client held two meetings where the tenants were informed about living in a passive house.



## 5 Villa Malmborg

In Lidköping close to Lake Vänern, a single-family house has been built to passive house standard. Lidköping is a city close to the lake but also surrounded by arable land, with approximately 40 000 inhabitants. The latitude is 58°27'55"N. The town is expanding and an old airport area, Majåker, is now divided into pieces of land for new dwellings. In this area, Villa Malmborg was built in two storeys with a separate garage building. The total living area is 171 m<sup>2</sup>.

### 5.1 Decision

The Malmborg family was living in a typical Swedish single-family house built in the 1970s with an annual energy demand of 28 000 kWh. The family liked their house and was getting on well but the house needed a great deal of maintenance that took a lot of time. They wanted a new built house with a low need of maintenance and low energy use. The first plan was to build a house with double wall panels of light-weight concrete, but this was a construction with large thermal bridges. The family found information about passive houses on the internet and thought it would be suitable for their wishes for a new home.

Together with architect Hans Eek, the family contacted many companies building single-family houses asking if they could build a passive house. It turned out to be difficult to find someone who wanted and was able to build a passive house. In the summer of 2004 the family got in contact with Vårgårdahus, a small company building wooden-frame single-family houses. They thought building a passive house was something in line with their company's values of high quality buildings with a low energy use.

In the first year of the planning process, the general manager of Vårgårdahus also worked as the project leader of the passive house. The client had many ideas about the house, ideas that changed during the planning process. This took a lot of time and Vårgårdahus realized that a separate project leader was needed. In the middle of November 2005, a separate project leader was chosen to run the project. The structural engineer who

made the drawings was chosen to be the project leader. He had never worked as a project leader before.

Also in this project a new type of contract work was used that never had occurred in the project where he had worked as a structural engineer. The project was performed with Vårgårdahus as the general contractor and a local building company that was responsible for the work on site. Usually, the responsibility for the project is divided in half between Vårgårdahus and the local building company. Working as a general contractor took more time than usual. Since this was something tried for the first time it was difficult for both the general contractor and the local building company to know what they were responsible for and what decisions to take. Many people have been involved in the project and this type of project was new to everyone.

Vårgårdahus is a free-standing subsidiary company to the local building company Tommy Byggare. Vårgårdahus produces about 120 single-family houses a year and have an annual turnover of MSEK 120. The houses are sold from Malmö in the south to Stockholm as the most northern part, but mainly in the western part of Sweden.

## 5.2 Basic requirements

The main requirements set up in an early stage of the project are listed below.

U-values:	Windows: 0.85 W/m <sup>2</sup> K Outer wall: 0.10 W/m <sup>2</sup> K Roof: 0.08 W/m <sup>2</sup> K Floor facing ground: 0.09 W/m <sup>2</sup> K
Airtightness:	0.2 l/s, m <sup>2</sup> at 50 Pa.
Acoustics:	Swedish Class B, including walls between apartments and system of beams. In living rooms and bedrooms this means that 26 dB(A) is the highest allowed sound level from interior installations and in kitchen 35 dB(A) is allowed. Noise from outside should not be higher than 26 dB(A) in rooms and 31 dB(A) in kitchens (SS 02 52 67 utgåva 3, 2004).

Air heat exchanger efficiency:	85%. The efficiency should be checked during the first year.
Solar collectors:	No
Drainage heat exchanger:	No

### 5.3 Planning

In the summer of 2004, Vårgårdahus were working on a new house for their catalogue, a “compact” house. With this as a basis, the architect and the structural engineer at Vårgårdahus made drawings of the passive house according to the wishes from the client (Figure 5.1). The house was specially designed and was not a house from Vårgårdahus regular range. In the planning process different designs of the house were calculated regarding energy use, trying different sizes of windows, different shapes of the rooms etc, as the work progressed.

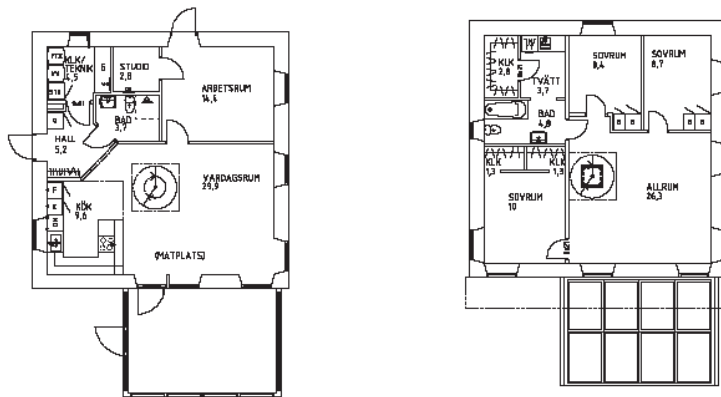

Figure 5.1 Early design of the house (Vårgårdahus).

Together with the project leader a time schedule for the project was decided and the foundation work was planned to start the first week in June, 2006.

In February 2006 the client realized that the house was too small and that they needed a separate working room. The first idea was to put this working room in the garage and to join up the garage with the main building. However, the outer door between the working room in the garage and

the house would need to be frequently open, to let the children run in and out. The garage was not designed according to the passive house standard and is heated with radiators to at least 20°C. With the door continuously open, these radiators might heat the house as well. Therefore, instead a working room area was included in the house, adding space at the north end on the ground floor, see Figure 5.2.

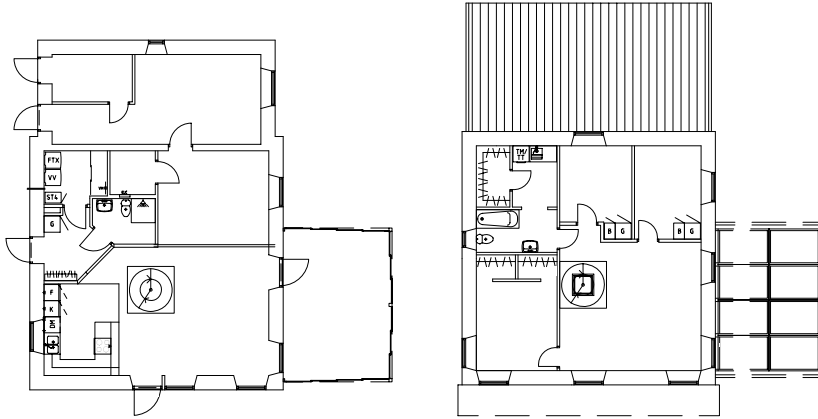

Figure 5.2 Final design of the house (Vårgårdahus).

The client thought about getting storm vestibules round the outer doors. Vårgårdahus said this would be an additional cost of SEK 80 000 and the client then decided not to have this solution.

Normally, it takes 10 months from the time when the client orders the house until she gets the key and can move in. In this project, almost twice as much time has been used. The project leader said that much time has been used to adjust to the new type of contract work. Also, many different solutions have been tried along the planning process, for instance regarding the heating system. This has taken much time and the project leader said that this could be avoided in the future by a planning check list with a description of what should be included. Then, this vacillating planning process could be avoided and the extra time needed for building a passive house could be decreased to one month.

## 5.4 Constructions

The planning process resulted in a house in two storeys with a total living area of 170 m<sup>2</sup>. The room height is 2.6 m at the ground floor and at

the upper floor has an inclined ceiling, going from 1.8 m to 3.5 m height (figure 5.3).

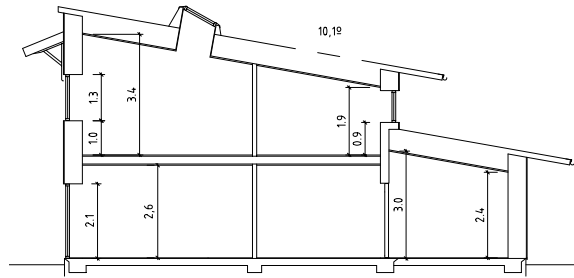

Figure 5.3 Section of the final design of the building (Vårgårdahus).

The U-values of the built construction were almost as planned at the start of the planning process (Table 5.1). The surface material in the hallway and the bathroom floors is quarry tiles and in the rest of the house there is parquet. The indoor walls were wallpapered or covered with painted wooden panel. In the bathrooms the walls were tiled (Figure 5.4).

Table 5.1 U-values used in the construction.

Building envelope	U-value (W/m <sup>2</sup> K)
Ground floor	0.10
Exterior walls	0.09
Roof	0.07
Windows, average	0.85
Entry door	1.00



Figure 5.4 Interior design and materials.

### 5.4.1 HVAC system

The house is heated by air. The air is supplied with an air-to-air heat exchanger. The heat exchanger has a heat recovery efficiency of approximately 85% according to the producer. The ventilation rate is 0.5 ach, with the kitchen fan not connected to the heat recovery system. Additional heat for the supply air is distributed by a waterborne heating battery with a capacity of 2.5 kW (14.7 W/m<sup>2</sup>). The hot water in the battery is supplied by district heating.

There is an automatic by-pass function for the heat exchanger in the unit, controlled by sensors in the exhaust air pipes. In the by-pass function the outdoor air goes directly to the supply air system without passing the heat recovery or heating battery. This by-pass function is necessary in the summer to ensure a comfortable indoor temperature. If the indoor temperature gets higher than normal, for instance when there is a party, but the outdoor temperature is +5°C or below, the by-pass function is automatically blocked.

When the occupants leave the house, the speed of the fans can be decreased to a low-speed level. If then the indoor temperature goes below the thermostat setting, the fan automatically speeds up until the temperature is at the right level. The filters in the ventilation unit need to be changed approximately twice during three years. If they are not changed, the efficiency on the heat recovery decreases and more electricity is needed for the fans. There are two fans in the unit, each using 210 W when the fan is working at full speed. On the supply air system, two silencers were mounted; one on each supply air pipe. There was one silencer mounted on the exhaust air system and one additional silencer on the exhaust air pipe that goes in to the recording studio (working room). The total air flow at full speed is 70/70 l/s.

In the bathroom, there is an electrically heated towel rail for additional comfort; a LVI TFR 62-C with a maximum power of 80W, manually regulated.

#### 5.4.2 Domestic hot water system

The domestic hot water is heated by district heating. No solar collectors were installed.

#### 5.4.3 Household appliances

The household appliances used in the project were chosen by the client.

Table 5.2 Household appliances.

Product	Brand	Notation
Dishwasher	Cylinda	DM92
Fridge/Freezer	Cylinda	KFT 3203-2
Stove	Cylinda	IH263
Cooker	Cylinda	IB30
Kitchen fan	Cylinda	Dragö EC90
Washing Machine	Cylinda	FTL46
Tumble drier	Cylinda	TK40
Microwave oven	Cylinda	IM20

The same brand has been chosen for all household appliances. Cylinda is not the standard brand for household appliances in Vårgårdahus productions. The client had good experiences from using this brand before. In

their choice of household appliances they focused on silent and energy efficient products, something they thought these products fulfilled.

## 5.5 Simulations

During the planning process, it was important to ensure that it would be feasible to build the house in the factory with the available devices. A normal wall in a house built by Vårgårda has a total thickness of 280 mm. This was the first time Vårgårdahus built a passive house. The first idea was to double their wall modules that are regularly used in their houses, to lower the U-value in an easy way.

This first suggestion of this double wall construction was simulated in DEROB-LTH calculating the energy demand for heating the building (Figure 5.5).

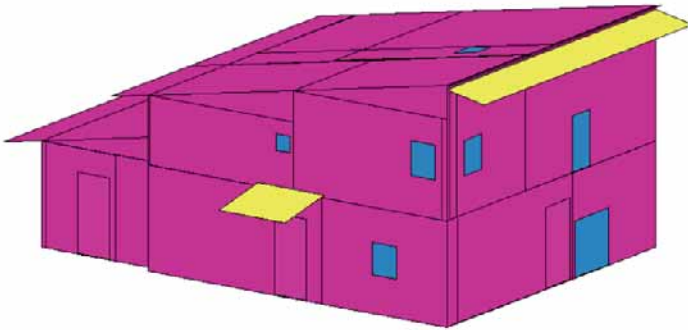

*Figure 5.5 Villa Malmborg simulated in DEROB-LTH.*

With a total of 380 mm of mineral wool insulation the results showed too high an energy demand for the house to be built as a passive house. The exterior wall was then improved using a total of 485 mm of insulation, where 335 mm was mineral wool and 150 mm eps insulation. Also, different window areas were tried. These two improvements gave a much better result regarding calculated peak load and space heating demand. The wall construction with a total of 485 mm of insulation was finally used.

It is important not only to place the windows where it would be best according to energy performance and indoor temperature; it should also be



a really nice house to live in. The architect suggested having larger window areas in the working room and in the bedrooms. This was not a big change of the total window area and worked well both regarding summer comfort and space heating demand. To enjoy the view from the living room on the ground floor even more, the architect suggested enlarging also these windows. Unfortunately, this gave too large a heating demand and therefore moderate window sizes were chosen. In the ceiling in the upper floor, an openable skylight was placed for ease of window ventilation.

Input data in DEROB-LTH:

Living area: 171 m<sup>2</sup>

U-values:

Floor facing ground: 0.103 W/m<sup>2</sup>K

Outer wall: 0.091 W/m<sup>2</sup>K

System of beams: 0.20 W/m<sup>2</sup>K

Inner wall: 0.47 W/m<sup>2</sup>K

Roof: 0.068 W/m<sup>2</sup>K

Outer door: 1.4 W/m<sup>2</sup>K

Windows: 0.72 W/m<sup>2</sup>K (not operable)

0.85 W/m<sup>2</sup>K (operable)

1.0 W/m<sup>2</sup>K (skylight window)

Ventilation:

Air leakage: 0.05 arch

Mechanical ventilation: 0.5 arch

Efficiency of heat exchanger: 80%

Ventilated volume: 85%

Orientation:

The building was rotated 45 degrees anti-clockwise from south

Soil resistance:

2.29 m<sup>2</sup>K/W

Ground reflection:

20%

Internal gain:

4.5 W/m<sup>2</sup>

Indoor temperatures:

The indoor temperature was set to 20 °C and 22 °C

For the studies of energy demand and peak load the maximum allowed indoor temperature was set to 25°C. Above this temperature, the occupants are assumed to reduce the temperature by using shading devices and/or opening windows.

Climate data:

The simulations were made with climate data for Jönköping

### 5.5.1 Calculated results

If the indoor temperature was 20°C the peak load for space heating was calculated to 9.2 W/m<sup>2</sup> and the energy needed for space heating was calculated to 15.2 kWh/m<sup>2</sup>a. When simulating the building with an indoor temperature of 22°C the peak load for space heating is calculated to 10.1 W/m<sup>2</sup> and the energy needed for space heating is calculated to 19.6 kWh/m<sup>2</sup>a.

Additional energy demand caused by thermal bridges should be added to the calculated result.

## 5.6 Tendering

A local contractor that worked with Vårgårdahus before was engaged to build the house. They carried out the foundation work, the construction work and the building services.

## 5.7 Planning deviations

In the Majåker area, where the house was built, a large field was developed with many new houses built in stages. The area of 55 single-family houses is in the fringes of Lidköping. About 300 metres away, there is a wood; otherwise the area is arable land. This area is connected to the district heating system and according to the regulations all new houses built at Majåker should be connected to district heating. It was a costly process for the local district heating company to construct the heating mains with the pipes for district heating from the thermal power station in the centre of Lidköping to the Majåker area. The manager of the district heating company estimated the cost per building site to be SEK 108 000. (It is less expensive to connect dwellings located closer to the main town.) As a single payment each client paid SEK 23 000, to connect his dwelling to the district heating system. Since the heating mains cost much more per building connected to the system, each connection this far away from the district heating plant means a financial loss for the district heating company that needs to be covered by running costs; payments for energy use. If some people in the area decided not to connect to the district heating system, the loss for the district heating company would be even larger.

The client tried to avoid connecting their house to the district heating system. It turned out to be very difficult to break out of the district heating

obligation, but after long discussions, the client succeeded in their efforts. Instead of district heating, Villa Malmborg was then planned to have solar collectors for heating domestic hot water. A total area of solar collectors of 10 m<sup>2</sup> (2.5 m<sup>2</sup>/ person living in the house) could be mounted on the fixed solar shading on the upper storey facing south. The suggested angle of inclination was 27°. The round storage tank would contain 750 litres and would be well insulated to minimize the heat losses to the surroundings. An immersion heater would be mounted in the storage tank.

For the additional heat needed in the supply air system, an electrical heating battery was suggested. However, this was not an option for the client that wished to be independent of electricity for heating. Another solution was to combine the solar collectors with a pellets furnace for the auxiliary heating. A water jacketed pellet furnace has a total efficiency of 3-12 kW. It could in principle be placed anywhere in the building, since the ashes end up in a box that can be pulled out and emptied. The furnace has a door that gets warm when in use. The rest of the furnace is insulated and does not get warm. 85% of the heat in the furnace is used for heating water, the rest, about 2 kW, becomes heat losses, heating the surrounding air through the furnace door. Since the total peak load for heating Villa Malmborg was calculated to 2.3 kW, the heat from the pellet furnace would give too large an additional heat contribution.

The client wanted to have a fireplace in the glazed patio (Figure 5.6). If the pellets furnace were placed there, the heat losses from the pellets furnace could heat the patio. The pipes from the furnace to the storage tank would need to be carefully insulated when drawn through the house, and when bringing the pipes through the outer wall the holes would need to be closely sealed. Unfortunately, this turned out to be a too expensive solution for the client. There was no cost difference for connections between the systems; the difference was in the investment cost for the furnace and solar collectors.



Figure 5.6 Glazed patio. (Photo: Mikael Malmberg).

The least expensive solution except using electricity for heating was to connect to the district heating system after all. Since a decision had already been made that the client did not have to be connected to the system, a new discussion had to take place with the local district heating company, to find if the house was allowed to be connected again.

The problem was financial due to a political decision made two years ago. At that time the system for paying variable costs per kWh in the district heating system in Lidköping was changed. Earlier the cost was different depending on what was used as fuel for district heating. This made the price vary considerably during the year. The customers complained and wanted a fixed price per kWh all year round. The district heating company listened to the customers and made a fixed price per kWh based on the Retail Price Index (RPI), the fixed costs, the efficiency of the distribution system, the average price per MWh and the amount of MWh consumed in the household. In a passive house with solar collectors, the main purchase of district heating will be during the cold months when the fuel for district heating is the most expensive. Such days used to be expensive days to buy district heating, but after changing to the fixed price cost model these days cost as much as any other day. The local district heating company therefore thought that the energy used in a passive house should cost more. To change this, the company needed a political decision.

Finally it was decided that the house could connect to the district heating system. To be allowed to connect the house to the system, the solar collectors had to be removed from the planned domestic hot water

system. The local district heating supplier said that with solar collectors the temperature of the return water would not be as low as they required. The client was not so happy about this solution, but could not see any other choice.

The total planning process took much more time than assumed. First the application for building permit took a long time. This was partly because the design drawings used in the application were changed according to new wishes from the client. Also, the process of finding a suitable heating system, appealing against the connection to the district heating system and later on to be allowed to connect to the district heating system, took time.

## 5.8 Training

Before the work on site started, half a day of training was held at Vårgårdahus. The contractor, the carpenters at Vårgårdahus, the staff at Vårgårdahus working with the project, the architect and the client all participated in these four hours of training. The electrician and the plumber did not participate. They were having a run-through with the project leader at Vårgårdahus later.

During the training session first the architect Hans Eek described the basic ideas of a passive house, showed some examples from earlier projects and talked about what is important to bear in mind during the building process. The architect described the criteria of a passive house and how to fulfil these demands and the importance of thinking of the building as a system, the importance of airtightness and to combine it with a mechanical ventilation system. The talk about airtightness covered both the question about energy efficiency and the importance of avoiding moisture in the construction.

The training session then dealt with a more specific discussion about construction details. Illustrations were shown for the difficult erection components, one by one. The details were discussed between the carpenters and the structural engineer to be able to find the best way of mounting the wall panels. All connection points of the panels were creatively discussed and the mounting process was solved for all panels at this meeting.

During the training it was discussed how the building process should be handled if it rained. Normally, Vårgårdahus erects a single-family house in one or two days, not caring about the weather. The erection of the house was supposed to start on the 9<sup>th</sup> of October, 2006. It would be difficult to dry out the construction if it rained this day. A tarpaulin was suggested to cover the building site, but it was not possible to have a large

tarpaulin hanging in the way when the panels were lifted from the trailer. Everyone; the general manager and the building contractors, agreed that if it rained this day, they would need to wait with the erection. They also agreed about the importance of having a large tarpaulin on site, to cover the building site if it started to rain and when leaving at night.

## 5.9 The building process

No additional drawings were needed during the building process, only a few explanatory sketches. The project leader and the structural engineer have been on site on several occasions to solve difficulties. This has only been possible since the working site was located very close to their office. Otherwise this would have been too expensive.

It took five days to erect the house. Some complementary work was needed, but more or less five days. A normal house in two storeys usually takes two days to mount on site. The project leader had the responsibility for the carpenters and said that the questions were mainly ordinary building questions, not specific questions for building a passive house. First the carpenters tried to solve the problem on site. If they were not able to solve the problem, they called the project leader.

### 5.9.1 Foundation construction

The foundation work started at the end of May 2006. Since the piece of land was clay, the foundation was reinforced by 12 driven piles. The foundation was then filled up with macadam, 300 mm of cellular plastic and the concrete slab on top was 200 mm. There was no additional requirement regarding the relative humidity level in the concrete slab before putting on the floor covering; the ordinary recommendations for different floor coverings were used together with the Swedish building regulations BBR.

An electrical coil was supposed to be cast in the concrete slab to speed up the drying process of the concrete. This electrical coil was forgotten during work on the foundations. The client asked the carpenters about the missing coil the day before the the concrete was cast, but the carpenters had not received any information about a coil from Vårgårdahus. To be able to cast the next day and not to have to postpone the casting process, Vårgårdahus decided not to bother about the heating coil. The coil was only supposed to be placed in the slab as a safety margin and they thought it was not really necessary.

### 5.9.2 Loadbearing structure

The loadbearing structure was prefabricated and made of wooden frames. A steel beam, IPE 270, complemented the structure on the ground floor. The internal walls were a 95 mm wooden frame construction with mineral wool, covered on both sides with 13 mm gypsum boards.

### 5.9.3 Exterior walls

Prefabrication:

All panels in the walls were made of two parts, mounted on site with a polystyrene layer between. A house from Vårgårdahus is always prefabricated in panels at the factory in Vårgårda and then the panels are transported to the building site on a truck, see Figure 5.7.



*Figure 5.7* Wall panels transported to the site.

An ordinary house usually consists of eight panels or a few more if made with a dormer. This house was not chosen from the standard catalogue but especially designed by an architect. The double wall construction and the architectural design made this house contain 40 wall panels.



The wall panels were prefabricated in the factory on a working-table that can be turned. First one side of the wall was made, then it was turned upright, meeting the working table on the other side and was turned upside down, see Figure 5.8. Then the other side of the wall was made (Figure 5.9).



*Figure 5.8 Prefabrication of outer walls.*



*Figure 5.9 Other side of outer wall.*



The working tables are welded on the floor and can not be moved sideways. The passive house wall was too thick to be turned in one piece, the two working tables stand too close to each other. That was why the wall was made in two different layers; one inside and one outside wall.

The plastic foil was kept on a roller placed on the side of the working table and was drawn out covering the wall construction. Since the walls were designed by the architect and were not of standard height, the plastic was not wide enough to cover the whole wall in one piece and therefore had to be joined together. The plastic foil was attached with staples to the wooden frame (Figure 5.10). Another set of wooden frames was mounted on top of the first frames for additional sealing of the plastic.



*Figure 5.10 Mounting of plastic foil.*

It took 340 h in the factory to make the 40 panels. It usually takes 212 h to produce 8 panels for a regular house at the factory of Vårgårdahus or four to five days to produce the panels for a single-family house. In this project, the factory manager reserved eight days in the factory for producing the panels. The extra time was needed because the building contains 40 panels but also partly because of the new way of building the panels; to seal the plastic foil carefully and for the new type of construction.

The carpenters making the walls had special financial conditions for this project, usually they do piecework but here they had a special agreement with additional time. It turned out that the factory manager had estimated too many days for the work; it only took 5½ days to finish all 40 panels.

The production worked very smoothly when there was no tight schedule. On site the wall panels had a high accuracy and fitted perfectly with each other, a bonus from not having the production under pressure of time.

Erection on site:

The exterior walls were prefabricated and mounted on site. The contractor had six carpenters working with the erection process. Three carpenters from Vårgårdahus who normally work at the factory were helping the contractor on site; how to mount the right way and supervised how to handle the plastic foil to get the required airtightness. Normally, Vårgårdahus do not send their carpenters on site; this was an exception to guarantee that the panels were mounted correctly.

First, panels on the inner wall were mounted, see Figure 5.11. The inner walls consisted of gypsum board, a wooden frame construction with mineral wool and plastic foil. The wall was completed on the inside on site with another wooden frame construction for installations insulated with mineral wool and a gypsum board mounted on the inside (Figure 5.12).



*Figure 5.11 Mounting of inner slab.*



*Figure 5.12*      *Wooden frame construction for installations.*

Steel angles cast in the concrete slab showed where to put the wall on the slab. A thin layer of expanded plastic was placed underneath the wall, protecting the wall construction from the moisture in the concrete, see Figure 5.13. Then a layer of polystyrene was glued on the gypsum board on the surface on the inner part of the wall (Figure 5.14). The polystyrene was sawn up on site to make them fit perfectly (Figure 5.15).



Figure 5.13 *Moisture protection of wooden beam construction.*



Figure 5.14 *Polystyrene glued on the gypsum board.*



*Figure 5.15 Polystyrene sawn up on site.*

Glue was also put on the edges of the polystyrene, making the panels adhere to each other. The carpenters who glued the polystyrene onto the inner part of the outer wall said that they felt insecure since it was the first time for them to do this. They said it was tricky not to have anyone to ask if they were mounting the right way or not. They did not know how long it would take for the glue to harden and for how long the polystyrene would therefore stay flexible. It was important to be able to move the polystyrene somewhat, when mounting the exterior part of the outer wall. The glue made the polystyrene bend in a concave shape. Mounting the polystyrene at the factory would not be a better option, since it needs to be completed on site.

After the polystyrene was glued to the inner part of the wall, the system of beams was mounted on top of the walls. It was important to make sure that the plastic foil in the wall construction on the first storey was not crinkled in the corners when the floor construction was put on (Figure 5.16). Then the outer wall panels were put in position (Figure 5.17).



*Figure 5.16 System of beams mounted on top of the walls.*



*Figure 5.17 Outer wall slab is mounted.*

At the end of the first day of mounting, tarpaulins were spread over the building. Unfortunately there were not enough tarpaulins to cover the whole building. During the night there were a few showers. In a few places of the construction, some rain had penetrated between the insulation and the plastic foil. On the part of the building where there was no tarpaulin, there was about 2 cm of water on the concrete floor. This was removed by the client, using a vacuum cleaner. Later, the plastic foil was lifted up from the wall and the mineral wool was dried by fans. This drying process continued for three weeks, until the insulation was dry.

On the second day of erection there was also a light rain. It was difficult to decide if the work should continue. The carpenters thought there was too much fuss about it and thought they should continue. In normal houses, the rain never stops an erection process. This decision took a lot of time to make. There was no one on site taking the lead and no one was the obvious leader to make these important decisions. Finally, after calling and discussing with the staff at Vårgårdahus, it was decided to continue with the erection process.

The exterior walls consist of a wooden frame construction with mineral wool, wind board, air gap and outer wooden surface material. The façade material is wood panel, primed with ferrous sulphate mixed with silver stain. The silver stain was added to see what was painted, since ferrous sulphate is transparent. The silver stain will fade as time goes by. To simplify erection of the exterior walls, the lowest wooden panel on all wall panels was detached and mounted back again later, see Figure 5.18.





*Figure 5.18 Lowest wooden panel detached to facilitate the mounting process.*

It is recommended to paint the façades once more when mounted. When painting the façade it is important to cover window sills etc since ferrous sulphate might cause spots.

The carpenters were sceptical about using ferrous sulphate, saying it will cause rotting in the façade in only a few years. To find out how it actually works, an expert was asked. (Alf Bexner, 060926) He said that wood exposed to high moisture conditions for a long time will finally be damaged by rot. If the wooden panel is painted with ferrous sulphate, moisture is first absorbed in the wood and later this moisture is emitted from the wood when sun and warm air is drying the façade. This variation in moisture content would not cause any long-term moisture exposure.

Painting with ferrous sulphate accelerates aging of the wooden façade. Modern wood used in façade panels absorbs much water. When the water is dried out, it could cause cracks in the wood. This makes the façade look scabby, but will only on rare occasions cause damage. To prevent cracks in the wood, the wooden panels could be mounted with annual rings facing alternately upward and downward. This decreases the stresses in the boards and thus the cracks. Using this mounting process takes more time



than regular mounting and is often forgotten when the building process is rationalized.

That damage due to rot could occur around the head of a nail is also unusual according to the expert. Rot damage appears after long term moisture exposure, but round the head of the nail the wood can breathe unobstructed. It is important not to put the nails too close to the end of the board, since this easily causes cracks .

Windows:

The windows were bought from SP-windows, with a total U-value of  $0.71 \text{ W/m}^2\text{K}$  for the fixed windows, and  $0.85 \text{ W/m}^2\text{K}$  for the operable windows. The glass, the distance between the panes and the gas in the gaps were the same in both window types. This glass combination was also used in the terrace doors and resulted in a total U-value of the doors of  $0.95 \text{ W/m}^2\text{K}$ .

The delivery of the windows was delayed. Usually, the windows are mounted at the factory and in this project they were supposed to be mounted in the outermost outer wall construction. Waiting for the windows, the innermost outer walls were first made. When the carpenters finished all wall panels, the windows were still not delivered. The factory manager then decided that the windows had to be mounted on site.

The windows were mounted on the fourth day of the mounting process on site. The polystyrene was cut out in the window openings, angling the window bays to get more light into the rooms. In the openings, nailing plates were holding the three wall sections together (Figure 5.19).



*Figure 5.19 Nailing plates in window openings.*

Plastic foil was fastened using a stapler on the window bays, connected to the plastic coming from the wall construction. To know where to place the window, wooden support blocks were mounted on the façade. Two blocks were placed in the bottom window bay for the window to lean on. The window was supposed to be mounted 31 mm inwards from the outer façade, flush with the inner wooden panel but at this position only polystyrene was available to attach the windows to. Therefore, additional metal plates were mounted in the window openings to have something to attach the window sill to. If the windows had been placed flush with the façade instead, the window sill would have been able to be mounted in the wooden framework of the outer wall.

The late delivery of the windows which caused them to be mounted on site turned out to be a good thing. The carpenters realized that they would never have been able to saw out the bevelled window bays in the polystyrene if the windows had already been mounted. Also, mounting the windows on site made the construction easier to insulate and to get it airtight.

After the mounting process, there was a meeting held at Vårgårdahus in November 2007, where the carpenters discussed the work on the project. Only the carpenters usually working at the factory at Vårgårdahus did participate in this meeting, not the hired contractor. The carpenters said that one of the positive things with the mounting process was a great

commitment on site and the external interest with visits from the media, from interested people at the local authorities and others. Technically, the wall panels fitted extremely well in the construction and eased the working process considerably. The mounting process that was discussed and decided with the structural engineer and others at the opening meeting worked very well on site. The carpenters were happy that they succeeded in building the house and thought that everyone working on the erection process was very skilled.

The carpenters also thought they were lucky that almost no rain came during the erection process. They also thought it was a lucky coincidence that the windows were late so they had to be mounted on site, something that turned out to give a very good final result.

The carpenters said it was uncertain for a long time which of the carpenters at the factory was supposed to build the houses on site. On site it was also unclear who was in charge of the mounting process and they also thought it uncertain who was in charge of the constructions and who to call if for instance they had questions about the constructions of the wall panels. It was difficult to know what panel was supposed to be mounted where. Furthermore, the wooden façade on the upper parts of the gable did not match the rest of the façade. This was probably a mistake in the design process.

The carpenters wanted in the next project a better establishment on site regarding scaffolding and safety issues. The panels for the wooden framework were loaded in the wrong way on the truck, causing a more difficult mounting process than necessary.

#### 5.9.4 Roof construction

The outer roof construction has a slope of 10°, from the south façade to the north façade. The roof is covered with steel sheeting mounted directly on the roofing felt. The cardboard is nailed to a layer of matchboards, covering 500 mm of loose wool insulation. A plastic foil is placed under the loose wool insulation followed by a wooden frame construction of 45 mm insulated with mineral wool. Below, there is a layer of wooden panelling and then the ceiling material (Figure 5.20).



*Figure 5.20 Roof construction.*

A long discussion was held during the training process on how to get the loose wool insulation between the roof and the plastic foil. The final decision was to make a hole in the plastic foil where the tube spreading the insulation could be put. After pouring in the insulation, the hole was carefully sealed with an additional layer of plastic foil.

Experience showed that it turned out to be somewhat difficult to get the connection between the roof and the skylight window airtight (Figure 5.21).



*Figure 5.21*    *Skylight window.*

### 5.9.5 Ventilation system

The ventilation unit was placed in a separate room together with the connection to the district heating. It was the same carpenters from the contractor who built the house who mounted the ventilation system.

When the client moved in, the system had not been adjusted for the right air flows in the different rooms, something that was noted in the inspection report. This was taken care of by Vårgårdahus right away. Adjustments were made and the protocol showed that the same air flows obtained in the air devices as the planned air flows (70/70).

In the inspection report there were additional remarks regarding the ventilation system. There was no supply air in the studio and in the store room there was neither supply nor exhaust air, only two transfer units. The inspection report also noted a lack of condensation insulation beneath the heat exchanger and that the heat exchanger was not sealed round the incoming water pipes in the floor in the appliance room. Furthermore, external pvc pipes were not insulated.

The store room was not ventilated because in the planning process the room was supposed to be used as a storage room. Now, the room will be used as an office instead. It is important that the client decides about the

use of the rooms at an early stage to ensure that all rooms will be heated and designed properly.

The client had some problems adjusting the heating battery in the ventilation system. The cause of the problem was difficult to find. It turned out to be in the battery in the district heating system. This heating battery is dimensioned to fit an ordinary house, with a much higher energy demand for space heating. Therefore the temperature on the return water from the heating battery in this passive house, with almost only an energy demand for domestic hot water, gets too high. The high temperature causes no faults in the energy supply to the house, but is sending out alarms to the district heating company.

#### 5.9.6 Domestic hot water

The domestic hot water is supplied by district heating. Since the district heating battery for the house was not adjusted to the small amount of energy needed, the temperature of the return water was too high anyway, even without using solar collectors. A smaller sub-centre for the district heating system is needed. Another solution might be to connect the passive house on the return water from the house that is situated before it on the district heating grid.

## 5.10 Measurements

### 5.10.1 Airtightness

When all wallpanels and the roof were mounted, the airtightness of the building was measured. This was something specific for this project and not normally done by Vårgårdahus. Usually they measure the airtightness of the walls at the factory, before the house is mounted, claiming that if the carpenters follow the mounting instructions, the house will be as airtight as required in the regulations.

The measurement of the airtightness was performed in January 2007 by SP Technical Research Institute of Sweden. The surface area studied regarding air leakage included all the exterior wall areas, the roof and the surface facing the foundation. The measurement was made according to the European standard EN 13829:2000. All air leakage openings in the building were closely sealed and a board was placed in the entry door opening, see Figure 5.22.



*Figure 5.22 Measurement of airtightness.*

A variable speed fan was placed in the wooden board and a tube was mounted to the fan. The fan first created an indoor overpressure in six steps up to 55 Pa and then vacuum in six steps down to 55 Pa. The mean value of the air leakage at 50 Pa for vacuum and overpressure is the value of the building's airtightness. The outdoor and indoor temperature was also measured together with the wind speed.

The measurement results showed that at an overpressure of 50 Pa, the air flow was 168 l/s. At an under pressure of 50 Pa the air flow was 185 l/s. The mean value was 176 l/s. The total leaking surface area was 401 m<sup>2</sup>. This gives the airtightness of the building as 0.44 l/m<sup>2</sup>s. The required air tightness was 0.2 l/ m<sup>2</sup>s, and it was thus not fulfilled in these first measurements.

To detect the air leakage, the house was set under 25 Pa of under pressure. Then an air velocity sensor was used together with a thermo camera to detect where air was leaking. Most of the air leakage was detected round the windows and in the corners where the wall panels are connected. The large difference between the air flows at under and over pressure could be explained by, the plastic foil being "lifted up" by the over pressure, causing a larger air flow.



The client asked for an additional pressurisation test after the family moved in, since they think there is an air leakage around some of the windows. Another measurement of airtightness is therefore decided to be made during the evaluation process of the house. The metal nailing plates used in the mounting process of the windows were necessary to be able to mount the window sills. Unfortunately it seems that these plates are causing the air leakage. This problem was detected in the first measurement of the airtightness and was supposed to be sealed afterwards.

### 5.10.2 Moisture

Before the surface material on the ground floor was laid, the client ordered a measurement of the moisture content of the slab on the ground. It was performed by the local Anticimex company in January 2007. Measurements were made by drilling two holes in the concrete slab in two different rooms (Figure 5.23).



*Figure 5.23 Measurement of moisture content in concrete slab.*

The holes were drilled to a depth of 40% of the total concrete thickness of 200 mm. Measurements made two days after the drilling showed values of 97 – 98% of relative humidity in the concrete. Calculations in the program TorkaS showed that the relative humidity should be about 92%.



These first results of relative humidity were really high and the relative humidity needed to be confirmed to know how to act on the building site. Another measurement was made according to the RBK-method ([www.rbk.nu](http://www.rbk.nu)). The result showed a relative humidity in the concrete of 93.2% and 91.2%.

It is not recommended by any producer of wooden floor surface materials to mount a wooden material on a concrete slab with a RH of 91% or more. To decrease the risk of mould problems in the future, a solution could be to mechanically ventilate the floor construction. Then, an air gap is built up between the flooring material and the concrete by a closely sealed material made of several distance spacer blocks placed on the concrete slab. Air passes through the ventilation gap and is sucked out mechanically through a pipe connected to an outdoor fan. (This ventilation must not affect the normal ventilation in the house.) However, this solution is not used in this project. The parquet flooring is laid without ventilating the slab.

The quarry tile producer had guidelines of how to mount the floor, a method they call G12. This works best if the concrete slab has a relative humidity below 90%. But if the concrete slab has drainage, no additional moisture is added to the concrete slab, the surface is dry and the concrete slab is older than 1 month it is acceptable to use the G12 method. This is now used in the Villa Malmborg.

### 5.10.3 Further measurements

Starting in February 2008, measurements will be carried out regarding actual energy use, indoor temperatures, outdoor temperature, supply air temperature etc. The measurements will be in progress for at least six months.

## 5.11 Economy

The cost for the building site was a single payment of SEK 103 400 or SEK 21.75 /m<sup>2</sup>. The connection cost for water and drainage (without VAT) was SEK 26 940 plus SEK 24.50 /m<sup>2</sup>. The connection to the electricity grid cost SEK 17 500. An application for a building permit cost approximately SEK 30 000.

To connect the house to the district heating system, the client paid SEK 40 000. Every year the client pays a yearly fee of SEK 777 and the flexible cost is SEK 0.55 /kWh.

Vårgårdahus estimated the additional investment cost to be 10-20%. This can be improved considerably in the future when the process runs more smoothly.

The planning process took much more time than for an ordinary building project; the project leader used about 250 h, the architect, the salesman, the person at Vårgårdahus responsible for the project used about 100 h each. Some of the additional time used by the project leader can be explained by the extra visits he made to site compared with ordinary projects. The project leader thinks that most of the additional time has been needed because this is a first time project and did not conform to the regular routines regarding deliveries and performance on site. The project leader said that he had not enough time in this project to analyse problems that came up. He would have needed someone who took over his other projects, so he could have had more time for this project.

In future projects, the project leader estimates that the architect will need about 10 additional hours for planning a passive house and the structural engineer about 20 additional hours.

The company Vårgårdahus sees a risk that the passive house project takes a long time to finish. It is important for the company to produce many houses every year because they make money on each closed deal. Even if they get paid more for a passive house it is not profitable when the production time is so long.

The house was very well covered by the media, which also took time from the persons involved in the project. Local newspapers, national newspapers, television and radio were reporting about the project. This gave Vårgårdahus a lot of publicity, advertising that needs to be considered when the total economy of the project is summarised. This marketing value is hard to put a price on.

The final cost of the house is not yet summarized. The costs will be more closely discussed in the final thesis.

## 5.12 Additional experiences

The managing director at the company Vårgårdahus was changed in autumn 2006. At this time, the attitude towards the project changed; it became more important to finalize the project than building a house that is possible to reproduce. This reduced interest in building passive houses in the company occurred before the evaluation of the building process and the house and before the financial evaluation.

During spring 2007, the company was thinking of how they should continue with building energy efficient buildings. Even though the com-

pany is uncertain of building more passive houses, it is important for them that all their houses should have a low energy demand. Some basic passive house ideas will be part of the building process to accomplish the low levels of energy demand. The company is going to change the construction of their standard wall, moving the placement of the plastic foil to the inside of an installation layer, to ensure airtightness. Triple glazed windows with a low U-value will also be a standard in their future houses. These changes will face a broader market. If the heating system of the houses will change from the heat pump that is now used, it is difficult for the customers to compare a Vårgårdahus with other one family houses. The customers want to be able to compare – so Vårgårdahus will keep the heat pump in their houses. If the customer wants to choose another heating system, it is their responsibility. Vårgårdahus does not want to be responsible for a complicated heating system.

Vårgårdahus are now discussing if they will have one production line with passive houses that runs parallel with standard houses. The major issue is if something goes wrong. It is a great risk to take if it turns out that the houses do not work. Vårgårdahus wants to be able to take out insurance on future unexpected damage. Vårgårdahus thinks it would be much better to have this long time financial safety than subsidies for special projects, to take the risk of starting a passive house factory.



## 6 Additional analyses

During the design stage, of course different questions arise. Some of them are not dealt with during the design process due to lack of time or if the questions are more of a general character that could be of interest for future projects. In this chapter a few analyses of this character have been carried out. In the planned continuation of the research, more will be done and reported in the PhD thesis.

Additional analyses of the buildings in the three new built projects were performed with the program DEROB-LTH. The focus in the simulations varies between the projects.

For the one family house, indoor temperature variations were simulated to see differences between using wood as the loadbearing construction, compared with using concrete. Villa Malmberg was also used to simulate what would happen to the indoor temperature if no one uses the house during two cold weeks in February.

For the apartment buildings in Frillesås, a study of an alternative wall construction was made. The outer walls in the multi-family houses were prefabricated and mounted on site. The prefabricated walls were then completed on site by adding cellular plastic on both the inside and outside. The general contractor normally uses less insulation in his buildings. The construction with these less insulated walls is simulated in DEROB-LTH to see if it would be possible to use these walls for a passive house and still achieve a low space heating demand. The airtightness and the highly insulated foundation, roof and windows were kept the same as for the passive house.

Finally, for the multi-family house in Värnamo, simulations were made to see if there were limitations on heating the building with the supply air at comfort air rate and comfort supply air temperature, without using any additional radiators.

## 6.1 Temperature variations when the loadbearing construction in Villa Malmborg is changed

In the simulations, the same input data was used as in earlier calculations.

Input data:

Floor area: 171 m<sup>2</sup>

U-values:

Floor facing ground: 0.103 W/m<sup>2</sup>K

Outer wall: 0.091 W/m<sup>2</sup>K

System of beams: 0.20 W/m<sup>2</sup>K

Inner wall: 0.47 W/m<sup>2</sup>K

Roof: 0.068 W/m<sup>2</sup>K

Outer door: 1.4 W/m<sup>2</sup>K

Windows: 0.72 W/m<sup>2</sup>K (fixed)

0.85 W/m<sup>2</sup>K (operable)

1.0 W/m<sup>2</sup>K (skylight window)

Ventilation:

Air leakage: 0.05 arch

Mechanical ventilation: 0.5 arch

Efficiency of heat exchanger: 80%

Ventilated volume: 85%

Orientation:

The building is rotated 45 degrees counter-clockwise from south

Soil resistance:

2.29 m<sup>2</sup>K/W

Ground reflection:

20%

Internal gain:

4.5 W/m<sup>2</sup>

Indoor temperatures:

The indoor temperature was set to 20°C and 22°C. For the studies of energy demand and peak load the maximum allowed indoor temperature was set to 25°C. Above this temperature, the occupants are assumed to reduce the temperature by using shading devices and/or opening windows.

Climate data:

The simulation was made with climate data for Jönköping

### 6.1.1 Energy demand

#### Wooden construction

Since Villa Malmborg is built with the wooden frame construction, the calculated results presented in Section 5.5 can be used. For the actual wooden construction, the peak load for space heating was calculated to  $9.2 \text{ W/m}^2$  if the indoor temperature was  $20^\circ\text{C}$ . The energy needed for space heating was calculated to  $15.2 \text{ kWh/m}^2\text{a}$ . When the building was simulated with an indoor temperature of  $22^\circ\text{C}$  the peak load for space heating was  $10.1 \text{ W/m}^2$  and the space heating demand was calculated to  $19.6 \text{ kWh/m}^2\text{a}$ .

#### Concrete construction

In the simulations, the intermediate wood floor between the two storeys and the wooden internal walls were changed to 230 mm of concrete. The results of the simulations using the concrete construction show that if the indoor temperature was  $20^\circ\text{C}$  the peak load for space heating was calculated to  $8.8 \text{ W/m}^2$  and the space heating demand was calculated to  $13.7 \text{ kWh/m}^2\text{a}$ . When the building was simulated with an indoor temperature of  $22^\circ\text{C}$  the peak load for space heating was  $9.7 \text{ W/m}^2$  and the space heating demand was  $17.7 \text{ kWh/m}^2\text{a}$ .

Table 6.1 Differences in peak load and energy demand for space heating, between wooden and concrete construction.

Loadbearing material	Peak load ( $\text{W/m}^2$ )	Energy demand ( $\text{kWh/m}^2\text{a}$ )
Wooden construction - $20^\circ\text{C}$	9.2	15.2
Concrete construction - $20^\circ\text{C}$	8.8	13.7
Wooden construction - $22^\circ\text{C}$	10.1	19.6
Concrete construction - $22^\circ\text{C}$	9.7	17.7

#### Discussion

There are only small differences between the peak load for space heating and the energy demand when the loadbearing material is varied. The somewhat lower energy demand when the solid concrete construction is used might be explained by the higher heating capacity of the material compared to a wooden construction.

## 6.1.2 Indoor temperature

### Wooden construction

For the studies of indoor temperatures, no maximum allowed indoor temperature was set in the program. Thus, the simulations are based on no extra ventilation or shading devices being applied. The simulations therefore show the worst case scenario concerning the risk of excessive temperatures.

The actual ventilation rate was measured to 0.5 ach on the upper floor and 0.4 ach on the ground floor (AB LO Håkansson, 07-04-24). The supply air is let in on the ground floor in volume 1 and distributed by the ventilation system to the rest of the house, see Figure 6.1.

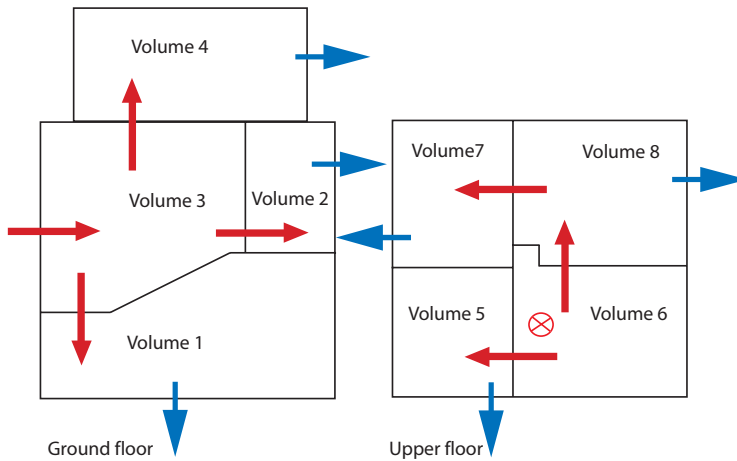
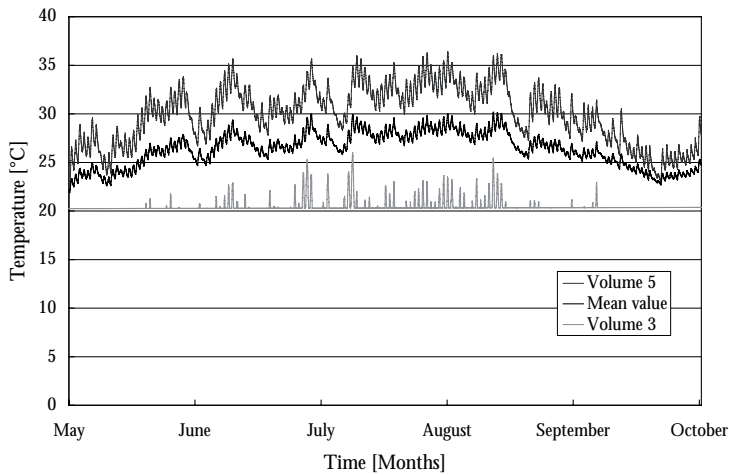

Figure 6.1 Air flow directions in the volumes as simulated in DEROB\_LTH, Villa Malmborg.

In the summer, the supply air goes through the by-pass system and not through the heat exchanger. The variation in indoor temperature during the summer months when the by-pass system is running was simulated in DEROB – LTH. Measured ventilation rates were used without air going through the heat exchanger. The indoor temperatures from May 1 to September 30 were simulated. The results in Figure 6.2 show that the mean value of the indoor temperature exceeds 25°C for a long time, using the wooden frame construction.





*Figure 6.2 Simulated indoor temperatures May 1 to September 30, using wooden frame construction. No extra ventilation or use of shading devices is assumed. The highest, lowest and the mean temperature for all volumes are drawn.*

The highest indoor temperatures would occur on the second floor (volumes 5, 6, 7 and 8). The highest indoor temperatures are received in volume 5, where there are a few hours above 35°C. The total number of hours above 25°C in volume 5, one of the bedrooms upstairs, is 3457 h, using the wooden frame construction. This simulation is made without additional ventilation from opening windows, that would in reality reduce the number of hours with too high temperature. Also the use of shading devices would decrease the risk of high temperatures.

#### Concrete construction

The simulations of indoor temperatures with the by-pass function were then made with the concrete construction; with internal walls and intermediate floor made of 230 mm of concrete. The calculated mean values of the indoor temperatures in all volumes from May 1 – September 30, using the concrete loadbearing construction, do not exceed 30°C (Figure 6.3).

The highest temperatures occur in volume 5, one of the bedrooms upstairs, where the total number of hours above 25°C is 2648 h. As in the calculation with the wooden frame construction, no additional ventilation is added for airing, which probably will occur in reality.

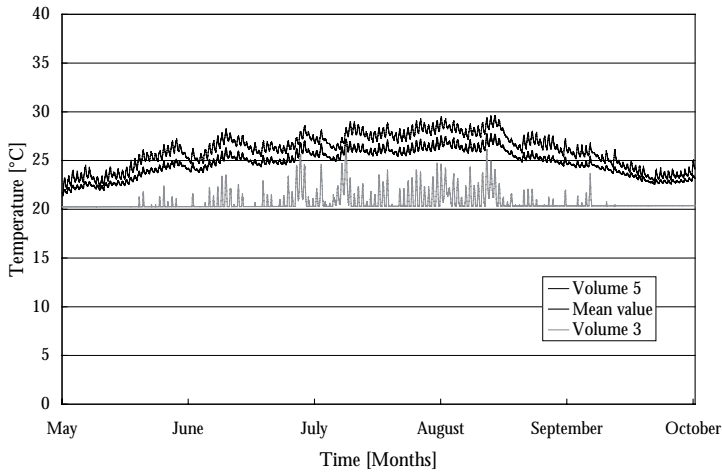

*Figure 6.3 Simulated indoor temperatures May 1 to September 30, using concrete construction. No extra ventilation or use of shading devices is assumed.*

Comparison between indoor temperatures using wooden frame construction or concrete construction

The calculated mean indoor temperatures with the wooden frame construction are compared with the temperatures with the concrete construction (Figure 6.4)

The calculated mean values of the indoor temperature using the wooden frame construction fluctuate a lot during the days. The variation in indoor temperature between the volumes is much higher using a wooden construction compared with a loadbearing concrete construction. The indoor temperature using the concrete construction is lower and more even.

The mean value of the indoor temperature in the house using the wooden frame construction is higher than 25°C for 2704 hours and during 1555 h using the concrete construction (Figure 6.5).

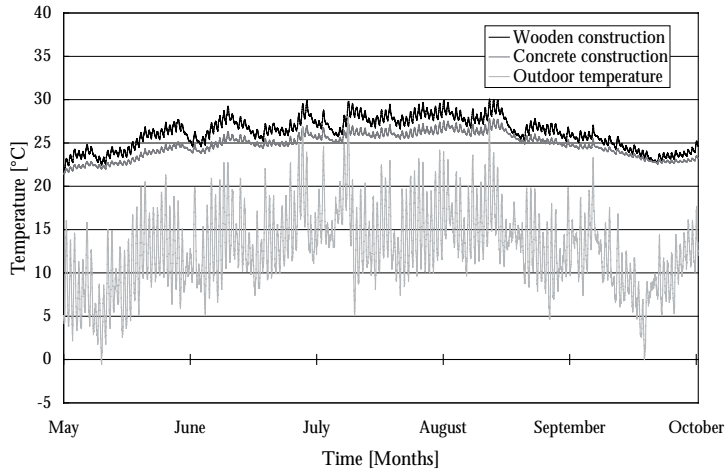

Figure 6.4 Mean indoor temperatures; wooden construction and concrete construction.

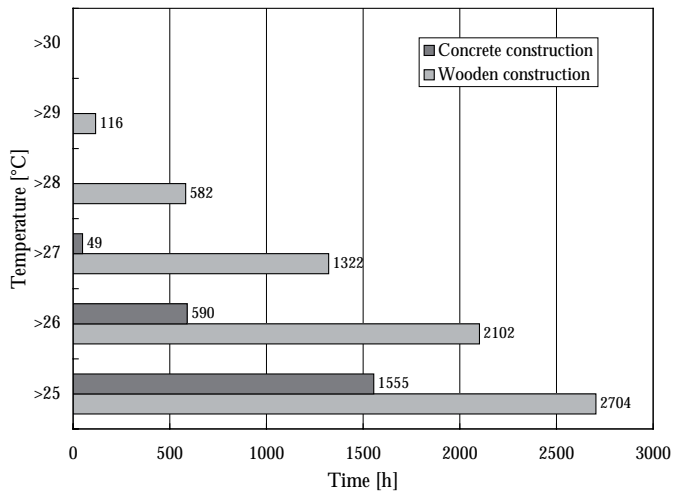

Figure 6.5 Mean indoor temperatures; hours above 25°C, wooden construction and concrete construction.

If the concrete construction is used, the mean value of the indoor temperature does not exceed 28°C, compared with 30°C using a wooden construction. The days with indoor temperatures of 35°C on the upper floor seem to be avoided by using the concrete construction, where the calculated indoor temperature never reaches 30°C.

## 6.2 Variation in indoor temperatures in Villa Malmborg when not using the house for two weeks

What happens with the indoor temperature if you want to leave the house for two cold weeks in February? To illustrate this, the internal gains in the simulations were decreased from 4.0 to 1.1 W/m<sup>2</sup>. [Wall & Smeds, 2001] Villa Malmborg is simulated in DEROB-LTH with the lower internal gains from February 1 to February 14. The actual measured air flow rates (70 l/s/70 l/s) are used in these calculations. The actual installed heating battery of 2.5 kW is used in the calculation as a limitation of the available heating capacity. The minimum indoor temperature is set to 17°C during the two weeks, to avoid too much cooling down of the building, trying to illustrate a realistic situation.

### 6.2.1 Wooden frame construction – temperature variations

Simulations are made using the actual wooden frame construction. The indoor temperatures during these weeks fall rapidly to 17°C (Figure 6.6).

When the family comes back and the house is heated both with internal gains of 4 W/m<sup>2</sup> and totally 2500 W from the heating battery, the indoor temperature increases. (Figure 6.7). The temperature rises from 17°C to approximately 19.5°C in only a few hours. However, it is after almost one week that the indoor temperature reaches 20°C due to the limitation of the heating battery. The indoor temperature rises above 20°C when the sun shines on the 7<sup>th</sup> day after the family comes back home.

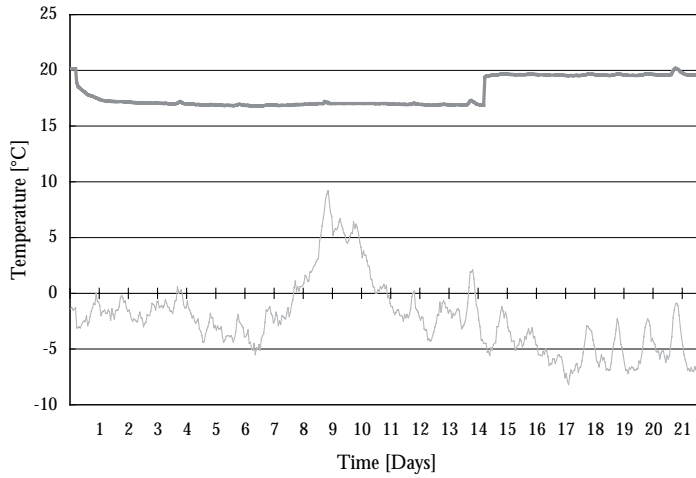

*Figure 6.6* Mean indoor temperature, wooden construction when not using the house for two weeks.

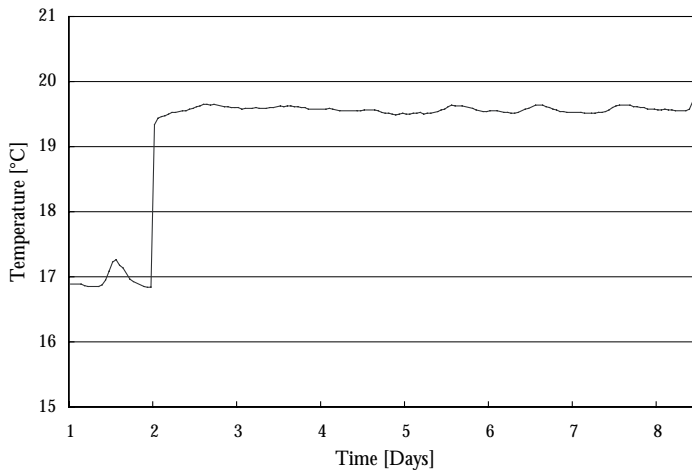

*Figure 6.7* Time to get the mean indoor temperature to 20°C, wooden construction. The family comes home on day 2 and the temperature reaches 20°C on day 8.

### 6.2.2 Concrete construction – temperature variations

The wooden loadbearing construction was changed in the simulations to a concrete construction of 230 mm. The calculated indoor temperature using the concrete construction behaves almost as in the wooden frame construction, see Figure 6.8 compared to Figure 6.6. When the family comes back it takes about 18 days to get a mean indoor temperature of 20°C (Figure 6.9).

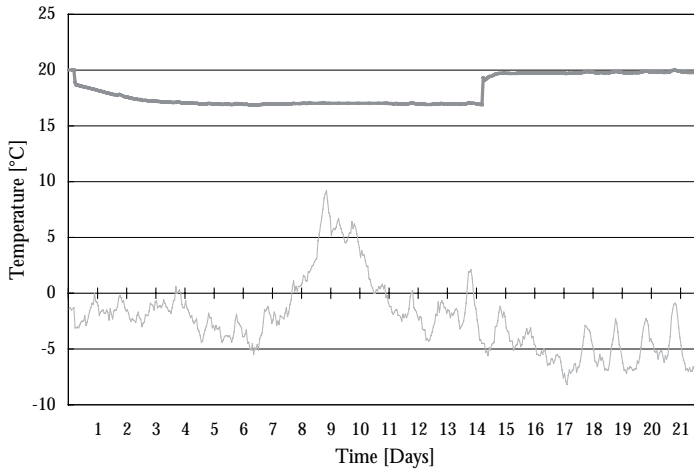

*Figure 6.8 Mean indoor temperatures using concrete construction when not using the house for two weeks.*

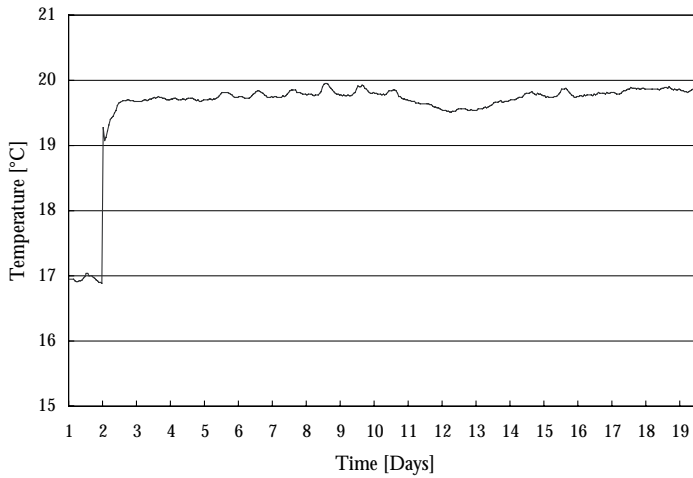

*Figure 6.9* Time to get the mean indoor temperature to 20°C, concrete construction. The family comes home on day 2 and the temperature reaches 20°C on day 19.

### 6.2.3 Influence of the thermal inertia when the house is unoccupied for a period

When the mean indoor temperatures in the wooden frame construction and the concrete construction are compared, it is seen that there are not so big differences between the construction materials (Figure 6.10). The fluctuation in indoor temperature in the wooden construction makes it reach the level of 20°C before the concrete construction, when the sun is shining on the 7<sup>th</sup> day after the family comes home. The more inert concrete construction rises above 20°C after 18 days. Both constructions are affected by the low outdoor temperature on days 11 and 12 but the concrete construction keeps a more even indoor temperature and does not fall as much as the indoor temperature in the wooden construction. The mean values of the indoor temperature in both construction materials rise rapidly above 19°C when the family comes back after two weeks. The power of the heating battery of 2.5 kW seems to be just right for this building construction.

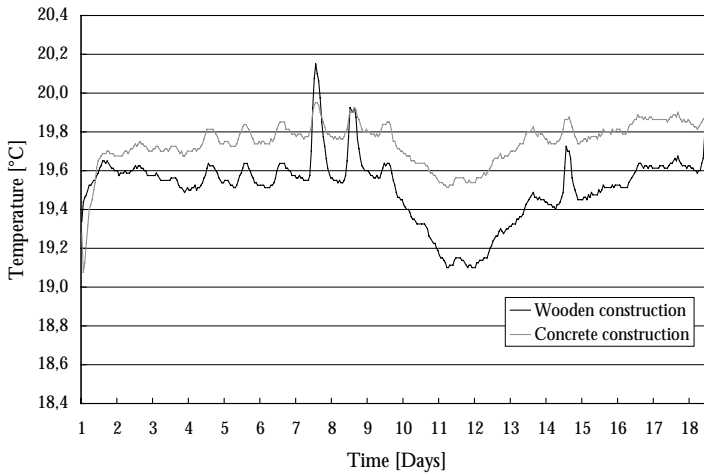

Figure 6.10 Mean indoor temperature; wooden construction and concrete construction when coming back after the house has not been used for two weeks.

In future research, calculations with lower allowed indoor temperatures when going away and also with varying ventilation air flows will be made.

### 6.3 Energy demand using regular insulation thickness in the multifamily houses in Frillesås

The outer walls in Frillesås were prefabricated and insulated on site with polystyrene insulation on both the inside and outside. The general contractor uses this method of building outer walls in regular projects but with less insulation. Normally 50 mm of polystyrene insulation is used on the outside, 195 mm mineral wool in the wooden frame construction and 45 mm mineral wool on the inside in the space for installations, see Figure 6.11.



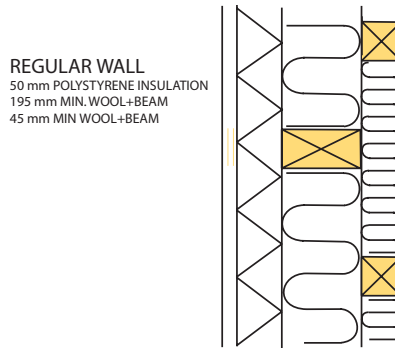

*Figure 6.11 Regular outer wall construction.*

In the passive house construction used in the Frillesås project the outer wall is insulated on the outside with polystyrene insulation of 100 mm, the wooden frame construction consists of 195 mm mineral wool, then 100 mm of polystyrene insulation is added on the inside completed with 45 mm of mineral wool in the space for installations (Figure 6.12).

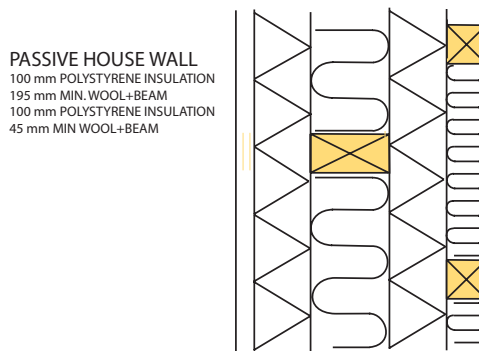

*Figure 6.12 Outer wall construction in the Frillesås project.*

The general contractor estimates the additional material costs for the passive house construction to be SEK 75 /m<sup>2</sup> for the outside polystyrene and SEK 100 /m<sup>2</sup> for the inside polystyrene insulation, a total of SEK 175 /m<sup>2</sup> for additional polystyrene insulation. The total surface area of one house is 322 m<sup>2</sup>. This gives an additional cost of SEK 56 350 /house with 4 apartments for insulation, compared with regular constructions and the passive house construction used in this project.

The outer wall construction regularly used by the general contractor is used for simulations in DEROB – LTH, to see if these outer walls with less insulation can be used and still achieve the peak load demand for space heating.

The heat load for space heating using the wall with less insulation is calculated to  $11 \text{ W/m}^2$ . This exceeds the passive house criterion of a peak load of  $10 \text{ W/m}^2$  for space heating. Using the passive house construction, the calculated peak load for space heating is  $8.5 \text{ W/m}^2$ . Using the passive house construction, the calculated total space heating demand with an indoor temperature of  $20^\circ\text{C}$  is  $3151 \text{ kWh/a}$  ( $9.6 \text{ kWh/m}^2\text{a}$ ). Using the regular construction with less insulation, the calculated energy demand is  $4868 \text{ kWh/a}$  ( $14.8 \text{ kWh/m}^2\text{a}$ ). The difference in the calculated total need of energy for space heating is  $1717 \text{ kWh/year}$  at an indoor temperature of  $20^\circ\text{C}$ .

The insulation costs will take quite a long time to pay back if the reduced energy costs are considered. However, the higher insulation standard will also enable a less expensive heating system and ensure high indoor comfort. To find the optimized passive house construction, both regarding peak load for space heating and investment costs, different insulation thicknesses should be tried in simulations.

## 6.4 Space heating with supply air in Värnamo

When a building is heated with supply air, the supply air temperature must not exceed  $52^\circ\text{C}$ . To avoid draughts and noise problems in the ventilation system the ventilation rate should be limited to the levels of hygienic flow, anyway needed to fulfil sufficient indoor air quality conditions ( $0.35 \text{ l/s, m}^2$  according to the Swedish building regulations (BBR 2006)). When planning the apartments in Värnamo, a higher supply air flow was used. This was to ensure that each apartment would definitely get an indoor temperature of  $20^\circ\text{C}$  and would not need to have too high a temperature for the supply air.

One of the multi-family houses in Värnamo was simulated in DEROB – LTH to see what supply air temperatures would be needed to keep an indoor temperature of  $20^\circ\text{C}$  without raising the ventilation flow, and to see if these temperatures would exceed  $52^\circ\text{C}$ . According to the climate data from Jönköping used in this simulation, the coldest period in the year is from the 24<sup>th</sup> of February to the 2<sup>nd</sup> of March. Climate data is taken from the program *Meteonorm* (Meteotest 2004).

In order to calculate the supply air temperature needed to heat the building to e.g. 20°C, Equation 6.1 can be used. The peak load for space heating  $Q$  is calculated in DEROB – LTH [W].  $V$  is the ventilation rate used in the building,  $\rho$  the density of air at 20°C,  $c_p$  the thermal capacity of air and  $\eta$  the efficiency of the heat exchanger. The outdoor temperature is taken from the climate data file for Jönköping, used in DEROB – LTH.

$$T_{supply\ air} = \frac{Q}{V \cdot \rho \cdot c_p} + T_{indoor} - (1 - \eta) \cdot (T_{indoor} - T_{outdoor}) \quad \text{Equation 6.1}$$

where

$$\begin{aligned} V &= 0.025 \text{ m}^3/\text{s} \\ \rho &= 1.2 \text{ kg/m}^3 \\ c_p &= 1000 \text{ J/kgK} \\ \eta &= 80\% \end{aligned}$$

The building in two storeys is divided into 8 volumes, as shown in Section 3.5, when simulated in DEROB – LTH.

#### 6.4.1 Simulations with indoor temperature of 20°C

In the first simulation regarding supply air temperatures, the passive house construction is used and the indoor temperature is set to 20°C. The results show that, with an indoor temperature of 20°C, the supply air temperatures never reach 52°C in any of the volumes of the building, see Figure 6.13.

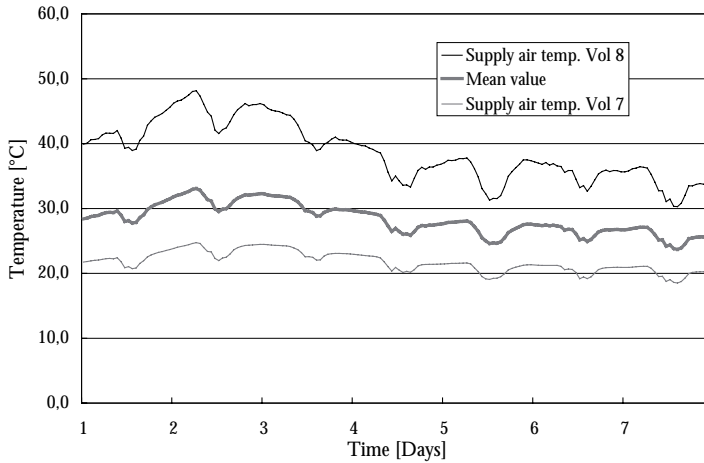

*Figure 6.13 Supply air temperatures using comfort ventilation rates with an indoor temperature of 20°C.*

#### 6.4.2 Simulations with indoor temperature of 22°C

Studies from the Lindås project have shown that tenants usually like to have a higher indoor temperature than 20°C. (Boström et al, 2003). The indoor temperature setpoint in the simulations is therefore raised to 22°C, giving a new peak load for space heating that, according to equation 6.1, gives new supply air temperatures, see Figure 6.14. When the indoor temperature is increased to 22°C in the simulations, the supply air temperature needs to be higher. The supply air temperature in Volume 8 will be higher than 52°C for 3 h.

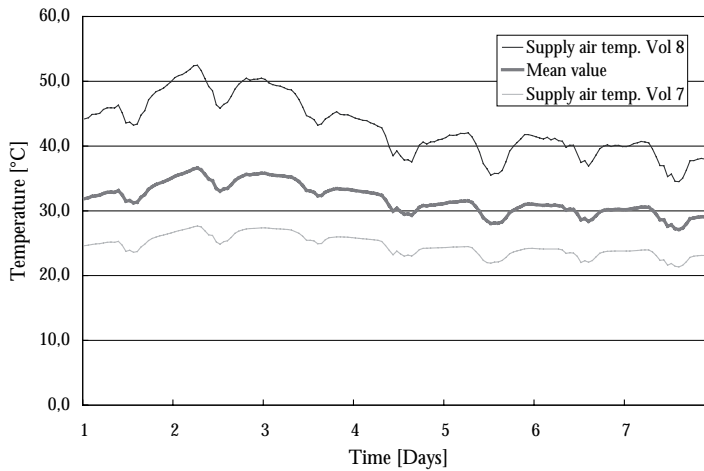

*Figure 6.14 Supply air temperatures using comfort ventilation rates with an indoor temperature of 22°C.*

#### 6.4.3 Simulations with indoor temperature of 24°C

A final calculation was made with an indoor temperature of 24°C in the building. The supply air temperatures are moderate in all volumes except for volume 8 (Figure 6.15). The number of hours where the supply air temperature exceeds 52°C is shown in Figure 6.16. To achieve an indoor temperature of 24°C using comfort ventilation rate, the supply air temperature needs to exceed 52°C for 85 h. During those hours an option is to increase the ventilation rate. In reality, a higher air flow is used.

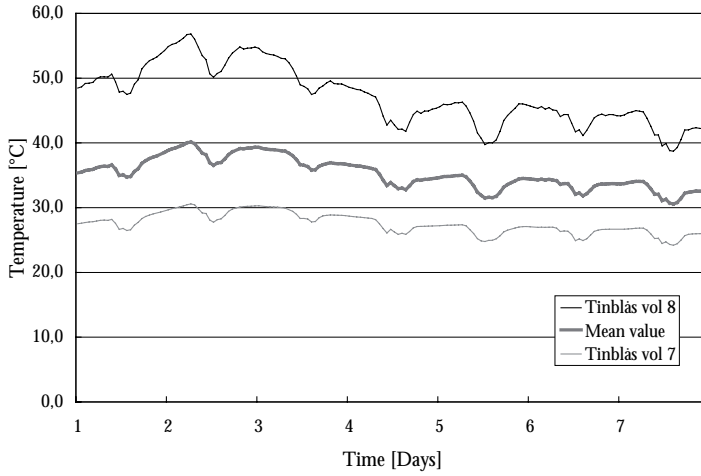

Figure 6.15 Supply air temperatures using comfort ventilation rates with an indoor temperature of 24°C.

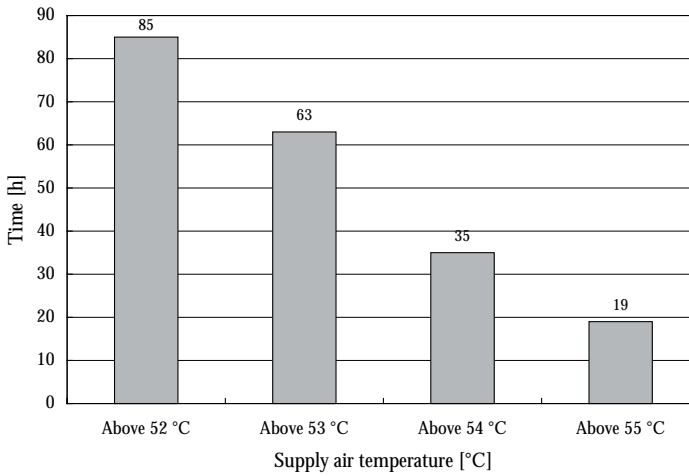

Figure 6.16 Number of hours in volume 8 where the supply air temperature exceeds 52°C with an indoor temperature of 24°C.

### Conclusions of supply air temperature simulations

The simulations show that it is possible to keep an indoor temperature of 20°C with the ventilation rate set to hygienic flow, without reaching temperatures of the supply air above 52°C. If the tenants want a higher indoor temperature, it seems impossible to avoid a higher ventilation rate to prevent too high supply air temperatures. Especially if the client wants an indoor temperature higher than 22°C, the air flow needs to increase.

When the air flow is increased, it is most important to plan the system carefully and to make sure that the supply air devices are working both for changing air flows and changing supply air temperatures. The indoor comfort must not be compromised





## 7 Project leadership

To reduce the energy consumption in Sweden, it is important that demonstration projects, such as for passive houses, are seen as something positive and will become duplicated. A non-functioning project group will probably not design and build something similar again. To build passive houses might be regarded as complicated and time-wasting with many factors of uncertainty. Well accomplished demonstration projects are seen as reference objects and are used as a basis for future projects. The project leader has a key role in this respect. Furthermore, the proud carpenters with straight backs are priceless as advertisers for building passive houses.

When a process is changed, expanding, decreasing or when starting up something new, special leadership is needed. The project leader needs to influence the project team to get to the right results. In the beginning of 1950, most of the leadership in projects was using methods from the military. There are still some project leaders who hark back to these methods but many have started to use a new way of leadership. When building a pilot project, a new leadership is necessary. There are no old projects to look at and copy. Both the building production and the leadership need to change to achieve the goals set up for the project. (Danielsson, Holmberg 2002)

During the working process with the three recently built passive house projects it turned out that the leadership differs much between the project leaders. Decisions are made, contractors are led and problems are dealt with depending on their different ways of leading their projects. None of the project leaders had built passive houses before and they were all very committed to their projects. Will the different ways of leadership affect the final result? Can a certain way of leadership make the difference between success and failure in a demonstration project? Is there a specific type of leadership to prefer when building a demonstration project?

The four project leaders in the three recently built projects were interviewed regarding leadership. They all received the 27 questions (see Appendix A) and had plenty of time to be able to prepare their answers. The questions refer to both the specific leadership in the demonstration projects, and also to their leadership in general.

## 7.1 To order something you do not really have knowledge about

Leadership and management are usually described as the ability to exert an influence on people and in this way influence activities, occurrences and activities. Nowadays it is more common to say that leadership is the ability to coordinate different participants to do homogeneous actions. The project leader is responsible for ensuring that deliveries to the project are on time but also to take care of disruptions that may occur. The most basic duty of the project leader is to reduce the uncertainty (Larsson and Larsson, 2005).

For the project leaders to be able to reduce the uncertainties in the project group, they first needed to straighten out all their own question marks. All project leaders got their knowledge of passive houses from external experts, for instance from the university, energy advisers or consultants that had this expertise. In one of the projects, this research was performed extra carefully when two investigations were carried out by two separate consultants to make sure that the apartments were not going to have too low indoor temperature.

In these demonstration projects many new actions, not regularly used in building projects, needed to be purchased and coordinated. A project leader must know precisely what to order and what actions by the contractors to call for.

Experiences from the demonstration projects show the importance of properly set up requirements. Everyone working with the construction of the building must know what they are doing and why. The set up requirements have been conclusive in getting the contractor to work the way the project leader wants. If the project leader forgot to check these requirements continuously, the contractor designed the building the way he thought was the best and the cheapest way. Further experiences show difficulties in being able to get all participants in the project to work in the same direction. The project leader had to convince the contractors about the new actions and the passive house way of thinking.

Initial training was performed in order to protect the project from disruptions. Experiences show that if only one contractor does not participate in the initial training, this can later cause delays in the project, when this contractor's work has to be redone to make the building work as a passive house. Training is very important to get everyone on site working in the same direction.

## 7.2 Right competence

In traditional projects the knowledge needed for the realization of a project can be acquired beforehand. In a demonstration project, the knowledge in the project team is built up along the way. The set up goals – even if they are detailed - are only limited and diffuse for the persons involved. In these kinds of projects it is natural that the knowledge about the project and its conditions is developed during the process.

To be able to develop the knowledge needed in these demonstration projects it was important to have the right competence in the planning group. The competence was secured in different ways; by having all the competence needed within the company of the contractor and by choosing the right external consultants.

One project leader said that the competence might have been too low in their project. This did not affect the final result, but the additional support from the project leader took much time from the planning process; time that could have been used in a better way.

## 7.3 To discover something unexpected

It is important to be prepared for unexpected incidents when making something new. To believe that someone could foresee an unexpected action is unrealistic; incidents will happen in all projects. The important thing is to minimize the time to react, to make the consequences of something unexpected as negligible as possible. The ability to discover something unexpected is considered to be so important that it has its own name; serendipity (Larsson and Larsson, 2005). It is very important that the project leader can understand, and therefore communicate, signals indicating new or unexpected conditions that might cause problems. What can it be that makes it difficult for the signals to turn into information that reaches the project leader? How can this process work easier?

Unexpected incidents generally result in four types of consequences;

- Give rise to a temporary interruption
- Cause a change in the organization, a change of the working methods or the like
- Lead to a fundamental change
- Result in the final stop of the project

In these demonstration projects the unexpected events have been solved in different ways. Sometimes it has been enough for the project leader to

have a discussion with everyone involved and together solve the problems. These unexpected events have not caused any major consequences, only short temporary interruptions resulting in small adjustments.

Another way for the project leader to deal with the unexpected events has been to first closely examine the extent of the problem and after that investigate if the problem could be solved and how. To avoid being alone in making the decisions, an external contact with e.g. previous experiences of building energy efficient buildings, can be used to discuss these kinds of problems. Examples of problems solved this way in these demonstration projects have been of financial nature and have been followed by fundamental changes in the project.

One of the project leaders said that it is of major importance to act as fast as possible when you as a project leader see signals that something unexpected has occurred. Decisions need to be taken rapidly. The right persons with the right expertise are put on the problem to solve it. At the same time the persons working on site must be given clear instructions about the matter. Unexpected events solved this way have resulted in temporary interruptions followed by changes; some small adjustments and some fundamental changes.

Experiences in these demonstration projects show that one important thing that prevents the unexpected incidents being discovered is that people hope to solve their own problems. The person it concerns tries as long as possible to keep the problem to himself and not ask for help or advice. It has been found very hard to admit a mistake or a lack of knowledge. To make it easier to ask for advice early, it is very important to have an open climate in the working group where signals like this are received in a good way. The project leader must focus on finding the best solutions for the project, not finding the scapegoat.

## 7.4 Leadership

There are three typical types of leadership;

- 1) The democratic project leader: The team is led by joint decisions and everyone participates in the planning process. The project leader looks on herself as a part of the team.
- 2) The authoritarian project leader: The team is led by orders and distinctive terms of reference. The project leader is keeping a distance from the team.

- 3) The *laissez-faire* project leader: The team is not led at all. The project leader neither gives credit or criticisms nor is trying to organize the project work.

#### 7.4.1 Leadership in the projects

The democratic project leader

The three types are all represented in these demonstration projects. In the project with the project leader that describes himself as democratic, the structure in the project is kept by closely following the set up agenda. This also keeps the project in general order. To achieve this, an external supervisor was employed in the project, partly to relieve the pressure on the project leader but also to have a close check on the project. Decisions regarding the project were taken by the project leader together with the board of directors of the building company; to have this back up was very important for the project leader. When solving a conflict, the project leader first specified the details of the conflict to see what it was actually about. Knowing this, a summary of these facts was presented to the persons affected by the conflict. The project leader also presented the consequences of different solutions of the problem. If a conflict occurred between two persons involved in the project, the project leader took an active part as a mediator. If the conflict still could not be solved after talking it through, the project leader himself took the decision regarding the solution.

When the project leader who said he is working in a democratic way was asked to describe his leadership in one word, he chose "Listening and Democratic". He said that it is really important to have big ears when supporting the foreman on site, to hear what they actually ask about and encourage them when they have done a good job. A good leader is a competent person you can trust, a confiding person, said the project leader.

The authoritarian project leader

The authoritarian project leader was keeping the structure in the project by strict orders. To maintain order in the project, a clear order of leadership was kept so that everyone knew who was doing what and when it needed to be done. Clear tasks and goals were seen as the ideal way to keep a confident project organization. The set up goals were explained in plain terms.

All participants in the project reported on their work to the project leader, for him to keep a continuous control. By listening to the participants, knowledge was received about why certain decisions were made or about incidents that had happened. When decisive decisions needed to

be made, the project leader listened to the background facts regarding a certain issue and took a position. This position about each certain issue was kept until he had worked his will. If his will is not worked through, he thinks he has no business to be in the project. He must work towards goals he believes in and if there is some kind of resistance against the way he wants the project to head, he tries to convince people who can market his opinions in the project. He thinks that there are things that cannot be compromised.

The authoritarian project leader thinks that to be able to solve a conflict it is of major importance to know what it is actually about. Is it power? Or prestige? An unclear organization creates a centre for conflicts, when the leader allows people to take positions at someone's expense. If a conflict occurs, the authoritarian project leader takes an active role to solve the problem.

To delegate tasks, a clear definition of the task was given out, by e.g. a list sent out in an e-mail. The tasks were well adjusted to each person's working area so that the project leader does not try to control something he has nothing to do with.

When the project leader who says he is working in an authoritarian way describes himself with one word he says "Empathy". A good leader must have empathy, ability to work with other people and be interested in people and be committed to his/her work. It is important not to be timorous and to have the ability to keep a distance between one's work and oneself.

The *laissez-faire* / democratic project leader

In the third project, the project leader described his leadership with "Humbleness". He was working somewhere between a democratic and a *laissez-faire* way of leading his project, using diplomacy to everyone involved in the project. Strict boundaries where everybody in the project knew what to do and what expectations they needed to fulfil created structure in the project. By settled meetings in the project group, order was created.

Before a decision was driven through, a dialogue was held with the persons affected by the issue. Then, possible solutions of the problem were discussed with an external expert, before the decision was taken together. To delegate a task, the project leader personally contacted the person it concerned and asked kindly if he could take care of this task.

Problems were solved by discussions, where the project leader participated actively. Potential conflicts would have been solved in the same way; a discussion with the person it concerned until a good solution was reached. In this particular project, no conflicts occurred according to the

project leader. The project leader said that a good leader is a person who is able to make uncomfortable decisions.

#### 7.4.2 Influence of the leadership on work on site and the final result

Earlier studies have shown that in solid projects, the authoritarian project leader type who concentrates on the results has worked very well. In a more unstable environment, the focus must be more on persons and democracy. In smaller projects with fewer people involved, it is easy to underestimate the need of planning, follow-up and co-ordination. This can lead to not enough time being earmarked for the project leader and may affect both the leadership and the direction of the project.

The demonstration project that ran most smoothly had a well updated project leader who could easily answer questions and in that way run the project forward. It seems that a pilot project could be equal to an insecure project, according to earlier research, in need of a firm but democratic project leader.

In the first project where the project leader has been working in a democratic way, he had done his homework well regarding passive houses. Questions asked by both the planning group and the contractors were easily answered. The project leader knew well what result he wanted and how to get there; something that made the work of the contractor run smoothly, not have to wait for answers. The job was ready on time with a very good final result. Everyone working with the project is satisfied and proud of the final result, even though they needed to work many extra hours.

The authoritarian project leader might not provide the best leadership in a pilot project. Here many unexpected problems occurred. The project leader presumed that everyone involved in the project was clear about the passive house concept and how to achieve the requirements set up for energy use. The persons in the project group who were uncertain about these issues did not dare to show their lack of knowledge since the people working with the project had a great respect for the project leader. Instead of reporting mistakes to the project leader, the contractors tried to solve the problems themselves. The communication did not take place because of fear of reprisals and therefore caused delays in the project. The unexpected events have been solved as well as possible, depending on when in the project they were discovered. The project leader in these cases acted in an exemplary way, taking quick decisions to solve the problem and move the project forward. Whether the problems that needed to be solved during the building process will affect the final result might show in later measurements. Nothing that indicates problems has so far been

found. In future projects, it is important to reveal early in the project if something is not understood, to minimize the consequences of mistakes made in the project that may affect the final result.

In the third project, the need of planning, follow-up and coordination on site was underestimated. It has been hard for the project leader to know what is expected from him. This made him feel insecure about taking important decisions. Waiting for decisions has caused a lot of frustration among the contractors. This could have been avoided if the project leader knew early what he had authority to decide about.

It is still possible to build demonstration projects with good results even if the project leader does not lead the project in an ideal way. Skilled contractors and external experts can together create a very good final result. However, it is expensive to make changes late in the project. Lack of good leadership might not affect the final result but the final cost. If the budget is tight, money might be taken from something that increases the quality to cover the additional expenses. Whether a temporary solution has a shorter lifetime will show after the houses are used for a while.

Lack of good leadership might also cause sickliness in the planning group or in the contract group, when people feel frustrated or get too much responsibility that they are not supposed to have.



## 8 Discussion and conclusions

There are some parameters in the passive house projects that have turned out to be more important than others. The studied projects are limited to residential buildings.

In the planning process, all participants need to work together. Traditionally, the architect starts with making the drawings and then gives these to the constructor who takes care of the construction design and details. The HVAC consultant then gets the drawings to ensure that the building will have a suitable indoor climate and designs the supply of domestic hot and cold water etc. Often the HVAC consultant also needs to ensure that the energy requirements will be fulfilled and tries with his best ability to reach the requirements with the already fixed design and construction. This way of handing over the baton is not a good way to plan a passive house. Everyone needs to work together to get the building design as energy efficient as possible. Also, much information can disappear between the different consultants when the baton is handed over. This can also be avoided when working as a team.

Sometimes it is not possible to build the house according to the construction details on the drawings. If there is time in the project, a good thing is to make some trials of the constructions, for instance to make sure that the requirements specified for airtightness are feasible. The solutions must be easy to build and easy to duplicate.

The clients need to set up requirements regarding energy efficiency, to decrease the energy use in new buildings. To know what requirements are reasonable, education of the clients is needed. The knowledge and experiences about passive houses need to be spread from clients who have already ordered passive houses, to other clients. It is important that old prejudices that are easily spread about e.g. airtight buildings, condensation on windows or problems with system air devices are explained and abandoned.

To have a result that has high quality and is ready on time, much of the responsibility rests with the project leader. If the project leader has done

his homework well he can easily answer questions that arise, both in the planning process and during construction. The project runs smoothly when people do not have to wait for answers. The project leader must know what result he wants and firmly steer the project in the right direction. Then all contractors are clear about the requirements set up and fewer unexpected incidents occur in the project.

It is also very important to give the client the right expectations. No passive house construction will be good enough if you expect to get something else.

A network for passive house builders might make the planning and tendering process easier; not only to help finding components but also to get examples of building constructions and experiences from other projects.

An easy way to make the building constructions would be to duplicate solutions from earlier projects. In these demonstration projects, the consultants and contractors have to work with requirements set up for U-values, airtightness etc. To save time and make the tendering process easier and decrease the uncertainty of building something new, examples of constructions are asked for. These should be standard examples of outer walls, roof and foundation constructions. However, there is a risk with presenting examples of constructions. They can be followed without considering whether they are the best solution suitable for the specific application. Also, the type and location of the building could influence the appropriate constructions to be used. Maybe new ideas are not tested and people think that passive houses must be designed in a certain way. Not so creative or experienced constructors might just take the examples and use them without question. All solutions must be optimized for the actual project, both regarding energy issues and economy.

Demonstration projects are a good way to gain knowledge about passive houses. To experience a passive house from the inside, feeling that it is not too cold, that the surfaces of the windows are warm and the floors are not too cold, is something of a revelation. Many of the contractors who visited the demonstration projects had a competitive look at it, that it was not something difficult and that they definitely could build like this – but better.

Everyone who participates in the project must be educated about the basic ideas of passive houses. The project leader must be a good listener to really hear what the consultants and contractors are asking for. Moisture content and airtightness must be checked up early and such checks should be a natural part of the building process.

It is important to plan the project right regarding seasons. The foundation construction should be cast during the warm season. To cast the loadbearing structure on site turned out to be time saving. The concrete is airtight and does not need additional work to reach the required airtight-

ness. Prefabricated outer walls can be mounted in a short time. This saves time but also decreases the risk of high moisture content, if the walls are mounted on a day without rain, snow or mist. The walls must be covered when mounted, by façade material or covered by a tarpaulin, to prevent moisture getting into the wall construction. A good way to get the window sills in the right angle in the bevelled construction is to use brick wedges. To hand on information obtained in the project a meeting could be held, weekly or every fortnight, so the carpenters could sum up questions or suggestions of improvement regarding constructions and solutions.

Experiences show that the fans in the air-to-air heat exchanger produce noise. To avoid this noise being propagated in the apartment it is important to build in the device. Even the most carefully planned ventilation system with the best silencers can not completely deaden the noise from the fans if the fans are not built in. The device can be placed in a walk-in closet or built into the wall, to deaden the sound from the fans. Notice also that the device needs to be connected to the sewerage system, since it produces condensation water.

To get larger scale production of passive houses in Sweden, more components suitable for passive houses need to be available on the Swedish market. Examples of such components are:

- Supply air unit with heat exchanger – right now there is almost only one supply air device model that is used in all passive houses in Sweden. The competition must increase both for development, e.g. for devices with a lower need of electricity for fans, but also to get the prices down.
- Supply and exhaust air devices – the devices used in passive houses must be suitable to use with variable air temperatures and variable air flows. These devices could with advantage have a good design.
- To avoid too thick outer walls, new insulation materials can be used. These super-insulation materials must be further developed for instance to be suitable for storage on building sites and to decrease the costs of these materials.
- The numbers of windows with low U-values on the Swedish market are increasing. Further development of these important components is however necessary. There are only a handful of window producers on the Swedish market today, which is a very pleasant development during the last two years. These windows need to be more easily available on the building markets, so people can buy energy efficient windows without having to wait during a longer (i.e. too long) ordering process. Otherwise it is often more easy to

buy the cheapest window available. If the products are easy to buy, the demand for energy efficient windows will increase and the prices can be lower. This is important also for the private home owners.

- There is a lack of entrance doors suitable for passive houses on the Swedish market. The one used in one of the demonstration projects is not available on the market. A development of entrance doors with low U-values is necessary.
- A combination of a heat exchanger and a heat pump - a compact unit - is very common in passive houses in Germany. The compact units deliver heat both to domestic hot water and to the supply air. The heat pump takes heat from both the exhaust air after the heat exchanger or from the outdoor air. There are at the moment no compact units developed for colder climates.

To build more energy efficient single-family houses, the salesman of the house has a major role when presenting the house to the client. The same way as he presents different choices of surface materials, kitchens and bathroom supplies, he should present different energy supply systems together with running costs. The client might not have a great knowledge about energy supply systems and will therefore not ask the salesman for different options.

A challenge to deal with to get the passive house technique into a large scale production is to make the projects profitable. Now, the passive houses are profitable in a long perspective, but many building companies are building houses speculatively, selling the buildings as fast as they can. They are not interested in energy use in the future. They want to build the houses for as low a cost as possible per m<sup>2</sup> to sell the houses at a high profit. If the competition with products suitable for passive houses can achieve lower prices, a passive house might become interesting also for such companies.

# Summary

To decrease the carbon dioxide emissions and put a brake on global warming, the use of energy needs to change all over the world. In Sweden, political decisions are made trying to get the energy supply cost effective with low negative effect on health, the environment and the climate. Renewable heat sources and energy efficient solutions are areas prioritised.

In June 2006, it was decided by the Swedish parliament that the energy use in residential buildings and premises should decrease by 20% per heated unit area before 2020 compared to the energy use in 1995. By the year 2050 the energy use should be halved. Before 2020 the dependency on fossil fuels for heating buildings must be broken off. In 2006 the sector of dwellings and service organizations used about 36% of the total energy in Sweden. To reach the set up goals, more energy efficient buildings must be produced and energy efficient improvements must also be performed on the existing building stock. Passive houses are buildings with a very low energy demand with a building technique that can be used both for new buildings and for renovation.

## Passive house concept

The passive house concept is not an energy performance standard, but a concept to achieve high indoor thermal comfort conditions at low building costs. The basic idea of a passive house is a well insulated, airtight construction with mechanical ventilation. Building components which are necessary in any case; the building envelope, the windows and the ventilation system, are optimized to make the need of energy for space heating as low as possible. Thermal bridges must be avoided, as must leakage of air through the building envelope.

To achieve a comfortable indoor climate in such an airtight building it is necessary to use mechanical ventilation. If the construction of a residential building ensures that the peak load for space heating is less than 10-16 W/m<sup>2</sup>, the ventilation system can also be used for space heating in Swedish climates. In Swedish residential passive houses, typical air flow rates are about 0.5 ach. When a ventilation heat exchanger is used, the supply air delivered to the living area is preheated by the exhaust air, which helps

to keep a comfortable indoor temperature. The heat exchangers should have an efficiency of at least 80% to minimize the ventilation losses. The maximum temperature of the supply air should be about 52°C. The unit also needs to be very quiet with a low need of energy for the fans and easy to clean and to change filters. Furthermore, the ventilation system has to be equipped with a bypass of the heat exchanger to keep the indoor temperature comfortable in the summer.

A standard has been set up to be used on a voluntary basis when building a passive house in Sweden, with for instance a few requirements on the building envelope to make sure that the building will function as a passive house. In addition to this standard the Swedish regulations BBR should be followed (BBR, 2006). Standard solutions for the integration of wood stoves into passive houses do not yet exist and need to be carefully planned in each project.

### Method

The first passive house project in Sweden was built in Lindås in 2001, ten years after the first passive house was built in Germany. The project was closely examined and showed good results both in satisfied tenants and high indoor comfort together with low energy consumption. Even though it was proved that passive houses can be built in Sweden, not many projects followed after Lindås.

In this research four passive house demonstration projects are built. The demonstration projects are located in the south west of Sweden. Three of the projects are new constructions and one is a renovation project. The results expected from this research project are to find guiding principles and tools needed for passive house planning, not only describing project specific solutions but to make the system solutions usable for planning in more general terms.

The method used in this research is to practically participate in these demonstration projects, joining as a part of the planning group giving advice and help to architects, consultants and to the client. In the planning process, general advice and conceptual solutions can be developed. Lack of components, systems and planning aids can be identified.

### Passive houses in Värnamo

In the centre of Värnamo in the southern part of Sweden, five buildings with a total of 40 rental apartments were built in 2005/2006 according to the passive house standard, as part of the public housing sector.

The project was built with an all-in-one contract. Before the major work started on site, everyone involved were gathered for an afternoon of training. As part of the training, models of the roof, outer wall and founda-

tion construction were made. These were after the training placed on site during the whole building process, something that was really appreciated by the carpenters. To avoid thermal bridges in the foundation construction, two L-elements were put outside the plinth for thermal insulation. The walls in the loadbearing structure were made of concrete cast on site. The exterior walls and the roof were made of wooden frame construction and mounted on site. Early measurements of the airtightness were made to know if the building method used produced the specified airtightness.

On all buildings solar collectors are mounted on the roof for domestic hot water production. Additional heat for domestic hot water is supplied from an electric battery. Every apartment has its own mechanical ventilation system with heat recovery with an electric heating battery. With an indoor temperature of 20°C the peak load for space heating was calculated to 8.3 W/m<sup>2</sup>. The space heating demand was then calculated to 9.8 kWh/m<sup>2</sup>a. In the simulation program DEROB-LTH, thermal bridges are not automatically taken into consideration. Additional energy demand caused by thermal bridges must be added to the calculated result or added separately in the simulation model. The wooden framework is taken care of in the above simulations, but not thermal bridges at specific connections and details.

The project was finished in time and the tenants moved in during the summer 2006.

#### Passive houses in Frillesås

The passive house project in Frillesås consists of three houses with 12 rental apartments. They were built in 2005/2006 as part of the public housing sector.

The loadbearing steel beam construction in the internal walls and the exterior wooden walls was prefabricated and completed on site. Separating the two storeys in each building is an intermediate floor with a prefabricated filigree system of beams. The roof is a prefabricated wooden construction. The attic is not mechanically ventilated, but ventilated by two air vents.

There is a separate centre for technical equipment with solar collectors mounted on the roof producing domestic hot water. Each apartment has its own air-to-air heat exchanger. Additional heat for domestic hot water and supply air heating is supplied by district heating.

The heating battery in the ventilation unit is placed before the heat exchanger. If the indoor temperature is 20°C the peak load for space heating was calculated to 8.5 W/m<sup>2</sup> and the energy needed for space heating was calculated to 9.6 kWh/m<sup>2</sup>,a.

The time to finish this project on the building site was 10 – 11 months and the tenants moved in on the 1st of December 2006.

Villa Malmberg, Lidköping

In Lidköping close to Lake Vänern, a single-family house has been built with passive house standard. The client wanted a new built house with a low need of maintenance and a low energy use and thought a passive house would be suitable for their wishes for a new home. The planning process resulted in a house in two storeys with a total living area of 170 m<sup>2</sup>.

The loadbearing structure was prefabricated and made of wooden frames, mounted together on site. The polystyrene insulation in the outer walls was cut out in the window openings, angling the window bays to get more light into the rooms. The outer roof is a prefabricated wooden construction that has a slope of 10°, from the south façade to the north façade.

The house is heated by air with an air-to-air heat exchanger. Additional heat for the supply air is distributed by a waterborne heating battery connected to district heating. Domestic hot water is also produced by district heating.

With an indoor temperature of 20°C the peak load for space heating was calculated to 9.2 W/m<sup>2</sup> and the energy needed for space heating was calculated to 15.2 kWh/m<sup>2</sup>a.

The family moved in to the house in April 2007.

Brogården, Alingsås

Alingsåshem, the public housing company in Alingsås owns 300 apartments in the Brogården area. The apartments in Brogården were built in 1970 and are in great need of renovation. The brick façade is worn out, the ventilation is not working satisfactorily and the apartments are not suitable for elderly or disabled persons. The tenants complain about draughts and low indoor temperatures.

First, one building with 18 apartments will be renovated. The building is in three storeys with three apartments on each floor. The loadbearing structure is made of concrete. The outer walls consist of an insulated wooden frame construction, with brick as the surface material. The houses are heated by district heating.

The apartments will be renovated to achieve the energy levels of a passive house renovation standard. The general manager at Alingsåshem divides the renovation cost into three. One part is energy saving, the second is the higher standard in the apartments (larger bathroom, new surface materials etc) and the third is the maintenance cost, the cost for the renovation needed in any case. Since the need of renovation was so extensive, the cost for making the building energy efficient is not dominating.



During autumn 2007 the planning process in the Brogården project proceeded and the renovation will start in March 2008. The building process, measurements and results will be presented in the final thesis in 2009.

#### Indoor temperature

Additional analyses of the buildings in the three new built projects were made in DEROB-LTH. In the one family house, indoor temperature variations were simulated to see differences between using wooden loadbearing construction, compared with using concrete. The results of these simulations show that the mean value of the indoor temperature in the house is higher using the wooden frame construction compared to the concrete construction. The calculated mean values of the indoor temperature using the wooden frame construction vary much from day to day. The indoor temperature using the concrete construction is much more even.

Villa Malmberg is also used to theoretically see what happens to the indoor temperature if no one uses the house during two cold weeks in February. Simulations are made using first the wooden frame construction and then the concrete construction. When the mean values of the indoor temperatures in the wooden frame construction and the concrete construction are compared, when the house is left empty for two weeks, it is clearly shown that the temperature in the concrete construction falls less than the temperature using a wooden frame construction. If you leave your passive house for a longer period during the cold season, it is important not to turn off the heat exchanger completely. Also, the indoor temperature must not be set back too much, to avoid too long a period of time to warm up the house when returning back home.

#### Insulation thickness

The outer walls in Frillesås were prefabricated and insulated on site with polystyrene insulation on both the inside and outside. The general contractor uses this method of building outer walls in regular projects but with less insulation. The outer wall construction regularly used by the general contractor is used for simulations in DEROB – LTH, to see if these outer walls with less insulation, and thereby a lower investment cost, can be used regarding the peak load demands for space heating.

The heat load for space heating using the wall with less insulation is calculated to  $11 \text{ W/m}^2$ . This exceeds the passive house criterion of  $10 \text{ W/m}^2$  as the peak load for space heating. Using the passive house construction, the calculated peak load for space heating is  $8.5 \text{ W/m}^2$ . With an indoor temperature of  $20^\circ\text{C}$ , the calculated difference in the total energy needed for space heating between the different constructions is  $1717 \text{ kWh/year}$ .

To find the optimized passive house construction, both regarding peak load for space heating and investment costs, different insulation thicknesses should be tried in simulations.

#### Supply air temperature

When heating a building with the supply air the supply air temperature must not exceed 52°C. To avoid draughts and noise problems in the ventilation system the ventilation rate should be limited to the levels of hygienic flow, anyway needed to fulfil sufficient indoor air quality conditions. One of the multifamily houses in Värnamo was simulated in DEROB-LTH to see what supply air temperatures are needed to keep an indoor temperature of 20°C without increasing the ventilation flow and whether these temperatures would exceed 52°C. The simulations were made during the coldest period of the year and show that if the indoor temperature is wanted to be higher than 22°C during this time, the supply air rate needs to increase.

#### Project leadership

To reduce the energy use in buildings in Sweden, it is important that these demonstration projects are seen as something positive and will become duplicated. A non-functioning project group will probably not build something similar again. To build passive houses might be regarded as complicated and time-wasting with many factors of uncertainty. Well accomplished demonstration projects are seen as reference objects and are used as a basis for future projects. The project leader has here a key role. During the working process with the three new built passive house projects it turned out that the leadership differs much between the project leaders with all three classical types of leadership represented.

Interviews were made with the three project leaders, to find if different ways of leadership will affect the final result. Can a certain way of leadership make the difference between success and failure in a demonstration project? Is there some way of leadership to prefer when building a demonstration project?

Experiences show that properly set up requirements are very important to get hold of the new actions made in a demonstration project and to reach the goal of a well functioning passive house. Everyone working with the design and construction of the building must know what they are doing and why. Initial training protects the project from disruptions and makes everyone on site work in the same direction. If only one contractor does not participate in the initial training, this can cause delays later in the project, when this contractor's work has to be redone.

It is important to be prepared for unexpected incidents when making something new and when the knowledge in the project team is built up along the way. People in the working group need to feel free to ask questions and admit a mistake or lack of knowledge. Signals like this must be received in a good way by the project leader with the focus on finding good solutions to these unexpected events. It is very important to keep an open climate in the project.

Earlier studies have shown that in solid projects, the authoritarian project leader who concentrates on the result has worked very well. In a more unstable environment, the focus must be more on persons and democracy. It seems that a pilot project could be equal to an insecure project, according to earlier research, in need of a firm but democratic project leader.

The one of the demonstration projects that ran most smoothly had a well updated project leader who could easily answer questions and in that way run the project forward. This avoids a lot of frustration in the working group, not having to wait for answers before being able to continue the work. Lack of good leadership might also cause sickness in the planning group or in the contract group, when people feel frustrated or are given too much responsibility that they are not supposed to have.

It is still possible to build demonstration projects with good results even if the project leader does not lead the project in an ideal way. Skilled contractors and external experts can together create a very good final result. However, it is expensive to make changes late in the project. Lack of good leadership might not affect the final result but the final cost. If the budget is tight, money might be taken from something that increases the quality, to cover the additional expenses. Whether a temporary solution has a shorter lifetime will show after the houses are used for a while.



---

# References

- Bexner, A., (060926) Oral communication, phonecall. Alcro Beckers, Stockholm Sweden
- Bodström, T., Glad, W., Isaksson, C., Karlsson, F., Persson, M-L., & Werner, A. (2003). *Tvårvetenskaplig analys av lågenergihusen i Lindås park* (Interdisciplinary analysis of the low-energy houses in Lindås park). (In Swedish) (Rapport ISSN 1403-8307) Linköping, Sweden, Linköping University, Tema Teknik och Social förändring.
- Boverket (2006). Regelsamling för byggande - Boverkets byggregler, BBR. *BFS 1993:57 med ändringar t.o.m. 2006:22*. (Swedish Building Regulations) (In Swedish). Karlskrona, Sweden.
- CENERGIA [www.cenergia.dk](http://www.cenergia.dk)
- Danielsson, A., & Holmberg, I. (red) (2002). *Ledarskapets olika skepnader – exemplet Hallandsås* (Different shapes of leadership – using the example in Hallandsås). (In Swedish) Stockholm, Sweden: Studentlitteratur
- Feist, W., Schnieders, J., Dorer, V., & Haas, A. (2005). RE-inventing air heating; Convenient and comfortable within the frame of the Passive House concept, *Energy and Buildings* volume 37 pp 1186 – 1203. USA: Elsevier Science Ltd.
- Forum för Energieffektiva byggnader, (2007). *Definition av Passivhus, version 1.0*. (Passive house definition) (In Swedish). [www.energieffektivbyggnader.se](http://www.energieffektivbyggnader.se)
- Haas, A. (2007). *Heat Delivery* IEA Task 28: Sustainable Solar Housing Volume 2, (p160) Trowbridge, UK: Earthscan
- Halse, A. (2005). *Passive Houses in Norway*, Oslo, Norway: University of Oslo/Aalborg University, Department of Innovation systems, social and ecological change.

Hastings, R. (2004). Breaking the “heating barrier”. Learning from the first houses without conventional heating. *Energy and Buildings* volume 36 pp 373-380. USA: Elsevier Science Ltd.

*IEA Task 28* (2005). International Energy Agency. <http://www.iea-shc.org/task28/index.html>

Kvist, H. (2006). *DEROB-LTH for MS-Windows, v1.2 Users Manual*. Lund, Sweden: Energy and Building Design, Dept of Construction and Architecture, Lund Institute of Technology, Lund University.

Larsson, A-C., & Larsson, R. (2005). *Projektledarrollen i praktiken* (The project leader in practice). (In Swedish) Uppsala, Sweden: Konsult-förlaget Uppsala Publishing House.

MINERGIE ([www.minergie.ch](http://www.minergie.ch))

Meteotest (2004). Meteororm 5.0 – Global Meteorological Database for Solar Energy and Applied Meteorology, Bern, Switzerland, [www.meteotest.ch](http://www.meteotest.ch)

Nationalencyklopedin [www.ne.se](http://www.ne.se)

Nilsson, N. (2003). *Organisation och ledarskap* (Organisation and leadership). (In Swedish) Stockholm, Sweden: Liber ekonomi.

Passivhaus Institute [www.passiv.de](http://www.passiv.de)

Passivhaustagung [www.passivhaustagung.de](http://www.passivhaustagung.de)

*Prop. 1996/97:84*. En uthållig energiförsörjning. (Sustainable Energy Supply) (In Swedish). Stockholm: Närings och Handelsdepartementet.

*Prop. 2000/01:130*. Svenska miljömål - delmål och åtgärdsstrategier. (Swedish Environmental goals) (In Swedish) Stockholm: Miljödepartementet.

*Prop. 2005/06:145*. Nationellt program för energieffektivisering och energismart byggande. (National program for energy efficiency and energy efficient buildings). (In Swedish) Stockholm: Näringsdepartementet

RBK-Metoden [www.rbk.nu](http://www.rbk.nu)

Sandberg, E. (2003). *Hus utan värmesystem* (Houses without a heating system). (In Swedish) Stockholm, Sweden: ATON Teknik Konsult AB.

Sandberg, E. (2003). *Känslighetsanalyser för Byggnader utan värmesystem*, (Sensibility analyses for Buildings without a heating system) (In Swedish) Stockholm, Sweden: ATON Teknik Konsult AB.

- Schneiders, J., & Hermelink, A. (2006). CEPHEUS results: measurements and occupants satisfaction provide evidence for Passive Houses being an option for sustainable building; *Energy Policy* volume 34 pp 151 – 171. USA: Elsevier Science Ltd.
- Schnieders, J. (2003). *CEPHEUS – measurement results from more than 100 dwelling units in passive houses*. ECEEE – Time to turn down energy demand. 2003 Summer Study Proceedings Vol 2 pp. 341 – 351.
- Smeds, J., & Wall, M. (2001). *Internal gains. Assumptions for simulations. Multi-family house, row house and single-family detached house*. Working Document Subtask B, IEA SHC Task 28, ECBCS Annex 38. Lund, Sweden: Energy and Building Design, Dept of Construction and Architecture, Lund Institute of Technology, Lund University.
- Smeds, J., & Wall, M. (2007). Passive House Solutions, Promotion of European Passive Houses, Enhanced energy conservation in houses through high performance design, *Energy and Buildings* vol 39 pp 273-278. USA: Elsevier Science Ltd.
- SIS SS 024310* (Swedish Organisation for Standardisation, second edition 1991-10-16). Dimensioning outdoor temperature – Peak load for space heating.
- SS-EN 13829* (European Committee for standardization, 2008-02-05). Thermal performance of buildings - Determination of air permeability of buildings - Fan pressurization method (ISO 9972:1996, modified).
- SS-EN ISO 12567-2* (International Organisation for Standardisation, second edition 2005-12-05). Thermal performance of windows and doors - Determination of thermal transmittance by hot box method - Part 2: Roof windows and other projecting windows.
- SS 02 52 67* (Swedish Organisation for Standardisation, third edition 2004-04-05). Building acoustics.
- Statens Energimyndighet. *Energiläget 2006*. (Energy status 2006). (In Swedish). Eskilstuna 2006.
- Wall, M. (2006). Energy-efficient terrace houses in Sweden, Simulations and measurements. *Energy and Buildings* volume 38 pp 627 – 634. USA: Elsevier Science Ltd.





# Appendix A

Questions asked to the project leaders used in Chapter 7;

Since this was a new concept that was going to be built, have you done a bit of rethinking regarding the leadership in the project?

How did the goal framing go?

How did you know what was important in the project when you have no experience of what you are ordering? Is it at all possible to create a competence as a client in this field without having any deeper knowledge and familiarity with the subject?

Did they, as project leaders, feel that there was lack of competence in the project?

Have you felt that you had control of the project?

Have the planning group been insecure? Has it been a major task in the project as a project leader to support this insecurity?

Have you felt that you have had support from the board of directors? Have you used any other external sounding board?

Was it difficult to have all in the planning group to work in the same direction?

Have you used milestones in the project? Part goals?

The ability to discover the unexpected. Give examples from the project. How do you act when you discover something unexpected? What were the consequences? What do you think it is that hinder the signals to be transformed in to information? Can you do something to ease the discovery and communication of such signals?

Did you have a finishing-off meeting?

What routines do you have regarding feedback?

How many projects did you run at the same time as the demonstration project? How many percent of your total working time did you need to spend on the demonstration project?

What kind of leadership do you think you exercise?

How do you create structure in projects?

How do you create order in projects?

Develop your look at:

Organization

Co-ordination

Control

Diplomacy

How do you drive through decisions?

How do you solve conflicts?

How do you prevent illness in the working group?

How do you solve problems that occur in the project?

How do you delegate working tasks?

How do you distribute the field of responsibilities?

How do you support the persons in the project group?

If you could describe your leadership with one word, what would that be?

What in the design of the organization do you feel affects you as a project leader?

What is characteristic for a good leader?









LUND UNIVERSITY

ISSN 1671-8136  
ISBN 978-91-85147-24-3